

CM 90S4

Gru idraulica a montaggio rapido
Hydraulic crane with quick assembling
Grue hydraulique à montage rapide
Hydraulischer Schnellmontagekran
Grúa hidráulica de montaje rápido



EN 14439 C25

FEM 1.001-A3

PROGETTO e COSTRUZIONE / DESIGN and CONSTRUCTION:
LUIGI CATTANEO S.p.A

CM 90S4



Nessun componente elettrico sul braccio e sulle parti alte della gru
No electrical component on the jib and the top of the crane

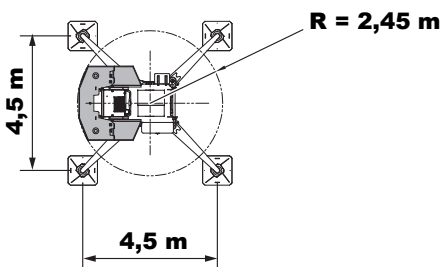
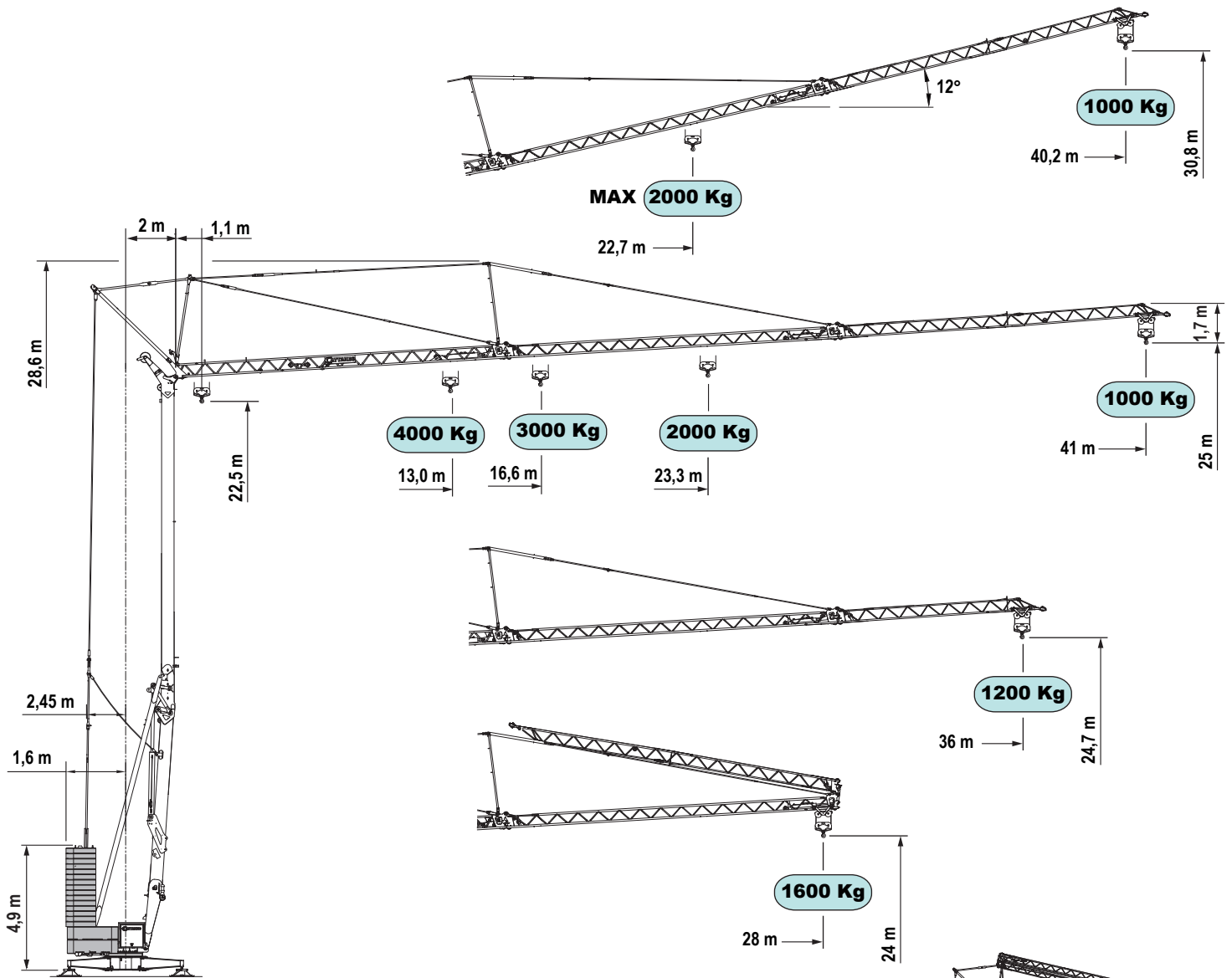

	kg	4000	3000	2500	2000	1900	1800	1700	1600	1500	1400	1300	1200	1100	1000
Curve di carico	kg	4000	3000	2500	2000	1900	1800	1700	1600	1500	1400	1300	1200	1100	1000
Load diagrams	m	13.0	16.6	19.3	23.3	24.2	25.3	26.5	27.9	29.4	31.1	33.1	35.5	37.8	41.0
Courbes de charge	m	13.1	16.9	19.6	23.6	24.6	25.8	27.0	28.4	30.0	31.7	33.7	36.0		
Lastkurven	m	13.0	16.6	19.4	23.3	24.3	25.4	26.6	28.0						
Curvas de cargas	m	13.0	16.6	19.4	23.3	24.3	25.4	26.6	28.0						

Prestazioni - Performances - Prestations - Leistungen - Prestaciones

	kW	kVA			1°R *	1°	2°	3°	4°
	18.5 inverter	21	↑	m/min	1	4	25	40	50
				kg	4.000	4.000	4.000	2.000	1.250
		↓	m/min	1	4	20	35	50	
			kg	4.000	4.000	4.000	1.500	1.500	
		2	↑	m/min	1	4	20	33	50
				kg	4.000	4.000	4.000	2.000	1.000
↓	m/min	1	4	20	35	50			
	kg	4.000	4.000	4.000	1.500	1.500			
	3.0 inverter		m/min		5	15 / 30 / 50			
	3.7 inverter		g/min		0.1	0.2 / 0.5 / 0.9			

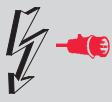
	1	21 kVA - 3 x 400V - 50Hz
	2	16 kVA - 3 x 400V - 50Hz ECO Power

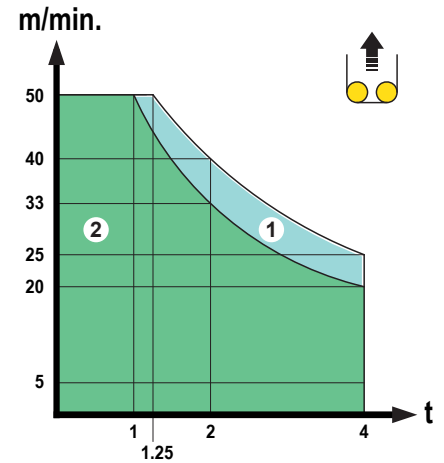

* Disponibile SOLO con radiocomando a manipolatore predisposto per questa funzione
Available ONLY with manipulator radio control suitable for this function

Montaggio - Erection - Montage - Montage - Montaje

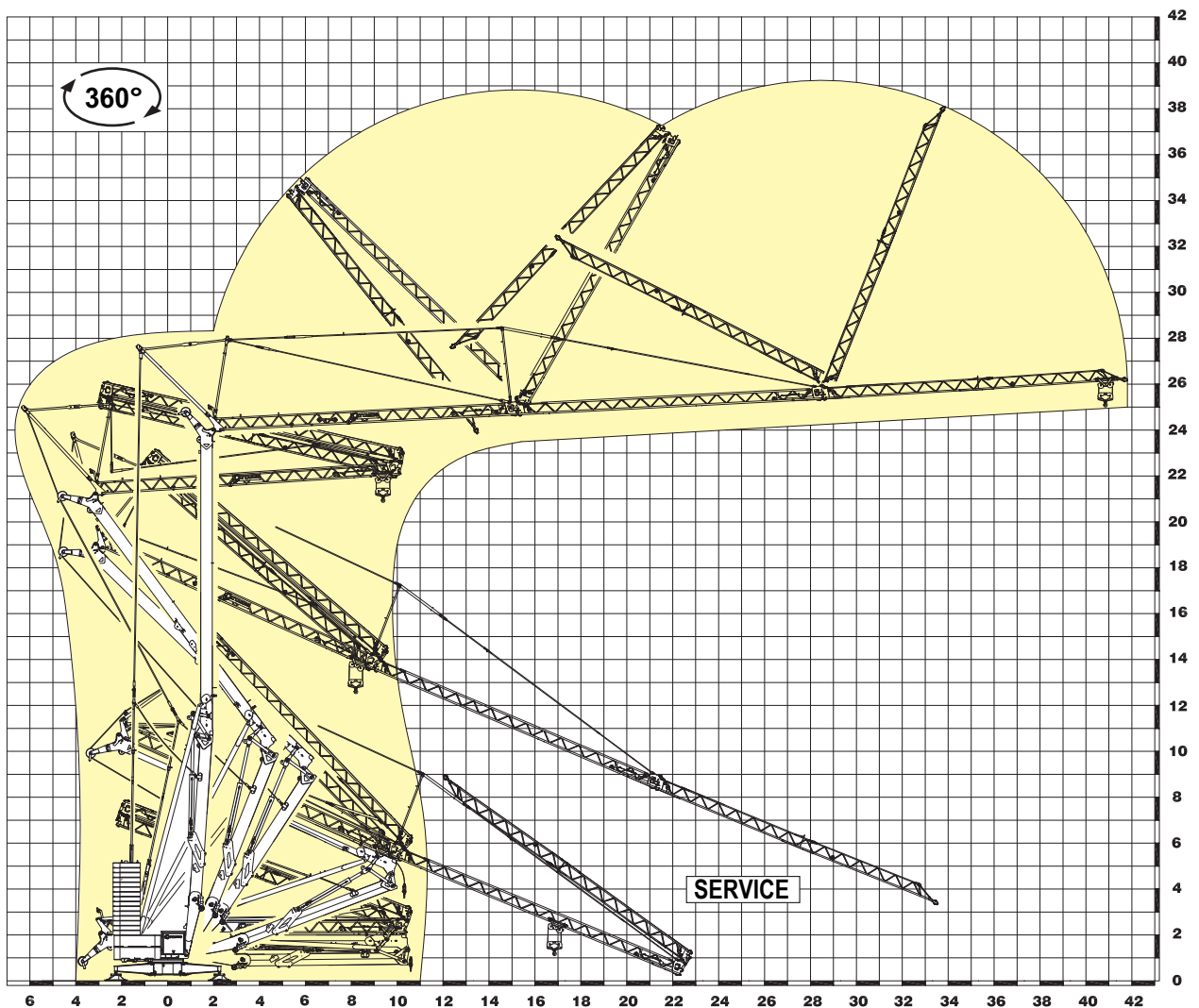

Documento commerciale non contrattuale - This commercial document is not legally binding
Document commercial non contractuel - Unverbindliches Vertriebsdokument
Documento commercial no contractual

CM 90S4

Contrappeso in lastre di cemento armato - Ferro-concrete ballast slabs
 Contrepoids en plaques de béton armé - Gegengewicht aus Betonplatten - Lastre en hormigón armado

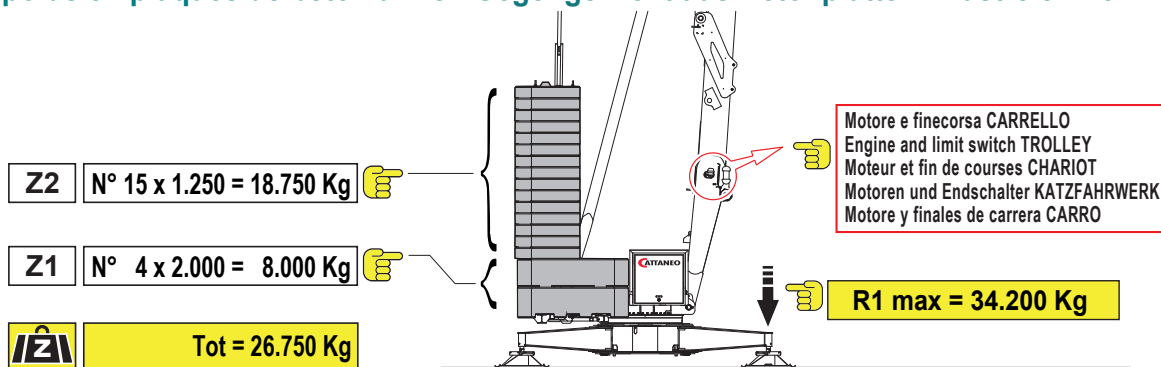

Trasporto - Transport - Transport - Transport - Transporte

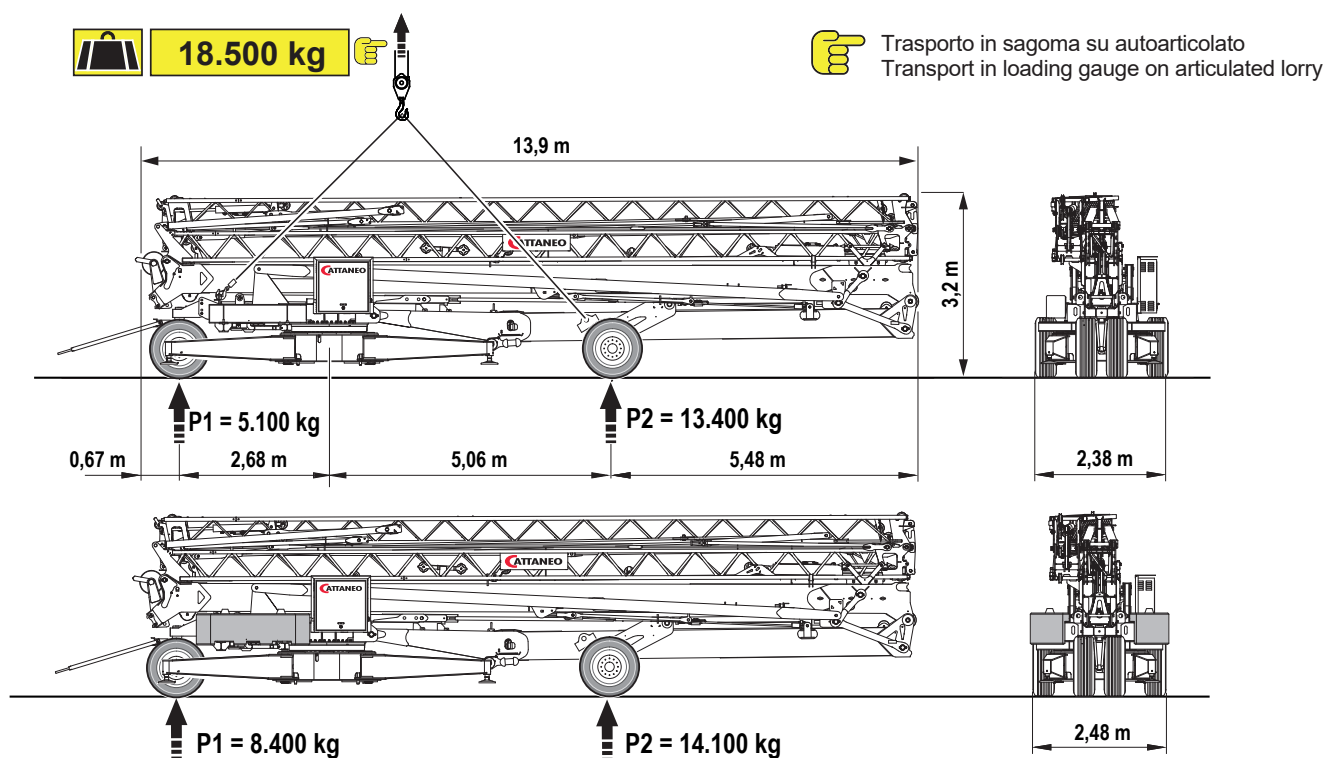

R120

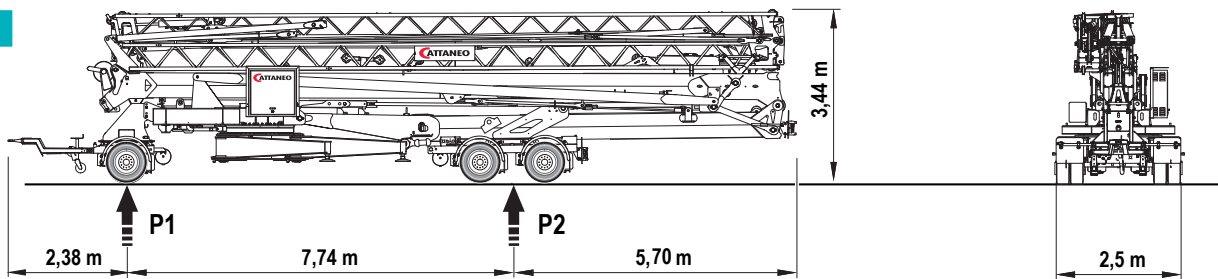

S020

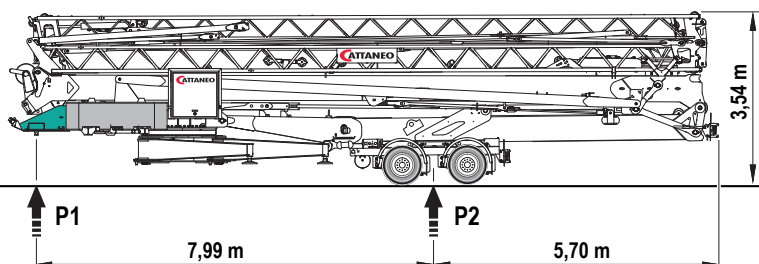

Otto	km/h	P1	P2	
R120	80	6.345	15.710	kg
S020	80	8.235	16.720	kg

Dir. 2007/46/CE