

NEW



AGRI LOADALL | 531-70/535-95/536-60/536-70/541-70

Gross power: 74.2kW/100hp – 108kW/145hp | Lift capacity: 3,100kg – 4,100kg | Lift height: 6,200mm – 9,500mm



JCB LOADALL: THE WORLD'S FAVOURITE TELEHANDLERS.

Telescopic handlers are now one of the world's favourite agricultural vehicles, and no wonder; these machines pack remarkable versatility, agility and performance into a compact, efficient package. Forward and vertical reach are simply unsurpassed by anything else on the farmyard, meaning that you can place more materials in less time.

JCB pioneered the very concept itself back in 1977, and we remain market leaders to this day. One reason for our success is that we are a company that manufacture a high percentage of our machines' componentry. This means that a JCB telescopic handler is perfectly matched to our customers' requirements, our components are fully integrated and its levels of build quality are unsurpassed.

Our JCB DIESELMAX engine, for example, is a highly productive unit that's designed to work in perfect harmony with our own full drivetrain, offering the kind of high-torque characteristics demanded by agriculture. And we manufacture all of our own chassis and booms, which means we can ensure the very highest levels of structural integrity.

Through our worldwide dealer network you have a 'one stop shop' for parts and service and the service intervals of a JCB Loadall are extended and our maintenance procedures are simplified. Our telescopic handlers remain highly desirable long after their initial purchase. So much so that, throughout the world, JCB telescopic handlers can boast high residual values.

All of which means that if you want the most productive, the safest and the most

serviceable telescopic handler with the lowest possible cost of ownership, then you really only have one choice: a JCB AGRI Loadall.

JCB AGRI Loadalls.

Part of our development process involved extensive customer input, meaning that any AGRI Loadall will be packed with innovative design elements to take on the tasks previously undertaken by front end loaders.

- With a telehandler, you won't need to hire as much manpower
- A JCB Loadall has superior productivity due to its rough terrain and reach capabilities
- Farm traffic can be reduced, boosting safety.
- The versatility of the JCB telehandler means it can do the job of many machines

Power, manoeuvrability, efficiency, durability, comfort, safety and cost-of-ownership are all therefore large parts of the package. Because we offer such a wide range of AGRI Loadall models, you can always find a perfect machine for any agricultural requirement.



HANDLING IT ALL WITH EASE



ULTIMATE PERFORMANCE, ULTIMATE PRODUCTIVITY.

DESIGNED TO MEET AGRICULTURAL DEMANDS, JCB'S LATEST AGRI LOADALL RANGE OFFERS UNPARALLELED PRODUCTIVITY, COURTESY OF REGENERATIVE HYDRAULICS, SUPERLATIVE PERFORMANCE, VERSATILITY AND EFFICIENCY. EXACTLY WHAT YOU'D EXPECT FROM THE WORLD'S NO. 1 TELEHANDLER MANUFACTURER.

With power and torque delivered at low engine speeds, the JCB DIESELMAX engine offers great responsiveness.

A productive machine.

1 A JCB AGRI Loadall is extremely manoeuvrable; the compact wheelbase and large steering lock angles save you valuable time on the farm, especially where space is limited.

2 4WD is standard, so traction is assured at all times. Optional 2WD is available at the flick of a switch too, minimising tyre wear and fuel use when roading. For improved performance on difficult terrain, opt for limited slip diff.

Productive lifting and hydraulics.

3 JCB's Smoothride System (SRS cushions shocks from the boom, improving load retention and increasing operator comfort (and therefore productivity) when travelling at speed on the road or on uneven fields.

4 The JCB quickhitch feature makes attachment changing quick and easy – coupling options include JCB Q-fit, pin and cone, and industrial.



Productive controls.

- AGRI Loadalls have three selectable steer modes. There's two wheel steer, which is ideal for travelling at high speed on the road; four-wheel steer for working in tight spaces; and crab steer for manoeuvring close to walls and farm buildings. Operators can switch modes on the move without having to line the wheels up.
- Multifunction single lever servo control provides fast and accurate load placement and control direction change is easy at the flick of a switch.
- For added versatility, all JCB Agri Loadalls are fitted as standard with a single boom auxiliary feature which can power a wide range of attachments and an option of twin auxiliary.



A SOUND INVESTMENT.

WE'VE DESIGNED THE JCB AGRI LOADALL RANGE TO PROVIDE SUPREME EFFICIENCY DURING OWNERSHIP AND AGRICULTURAL OPERATION. ALL MACHINES OFFER SUPERIOR RETURN ON INVESTMENT. GREAT FUEL EFFICIENCY AND UNPARALLELED RESALE VALUE, SO LOW RUNNING COSTS ARE A GIVEN.

EcoMAX efficiency.

1 The engine itself - the record-breaking DIESELMAX - is engineered to provide high torque at low revs, prolonging its life. It is also perfectly matched with the transmission, axles, cab and rams; all elements are designed and manufactured by JCB to work in perfect harmony for a high quality, durable total package.

2 JCB AGRI Loadalls are built to be as versatile and reliable as possible. You will find you can do more with a Loadall, more of the time, so you are always putting your investment to the best possible use.

3 Constant flow auxiliary service allows you to operate motorised attachments, such as bale spreaders, feeding/mixing buckets and sweeper collectors.

4 The DIESELMAX engine has been designed from scratch to give you performance you can depend on.



By producing high levels of power and torque even at engine speeds as low as 1300 - 1400rpm, the JCB DIESELMAX can provide fuel-efficient, smooth matching of transmission and hydraulics.



Reducing ownership costs.

- JCB Loadalls enjoy huge global demand due to legendary productivity and build quality levels – resale values have always been correspondingly strong.
- AGRI Super Loadalls are fitted with TorqueLock in 5th and 6th gears for greater speed, quicker journey times between farm and field, and reduced fuel consumption when roading.

High back-off brakes reduce viscous drag during roading and rehandling, which improves fuel economy by up to 2%.



STRENGTH AND DURABILITY.

WE UNDERSTAND THAT AGRICULTURAL WORK CAN BE INTENSIVE AND ARDUOUS. IT'S FOR THIS REASON THAT AGRI LOADALLS ARE BUILT TO BE AS TOUGH AS POSSIBLE, USING TOP QUALITY COMPONENTS AND INNOVATIVE MANUFACTURING PROCESSES. YOU CAN THEREFORE EXPECT A LONG AND PRODUCTIVE SERVICE LIFE FROM YOUR MACHINE.

Tough boom design.

1 Ultimate strength and durability is assured with large boom overlaps of over 1.0m. Hydraulic hoses can be vulnerable to damage, so ours are intelligently routed through the boom for maximum protection.

Built-in protection.

- 2 Bonnets are protected from damage by being side-mounted and recessed.
- 3 AGRI Loadalls with a lift height of 7m or more come equipped with fold-up rear lights that can be kept clear and well protected from typical farm damage.
- 4 Front and top screen roof guards for added protection from falling debris whilst lifting at height are an option.
- 5 Heavy-duty axle feet help to absorb the immense stresses generated during continuous heavy material rehandling.



The one-piece fully welded chassis maximises strength and minimises weight. For maximum structural rigidity, the boom on an AGRI Loadall is mounted low in the chassis. This guarantees superior over-the-shoulder visibility.

A tough inverted U-shaped boom pressing with fully welded closing plates provides superior strength; we've also reduced the number of joints and stress points across our integrated boom nose and one-piece closing plate.

Durable components.

- The AGRI Loadall range's stringent testing programme has included high stress loading of the chassis, boom and other key components, as well as repeated transmission use over thousands of typical agricultural work cycles, and prolonged use on our new rolling road facility.
- The centrally mounted lift, tilt and extension rams eliminate twisting and are held in place by centrally-mounted keyhole castings for even greater structural integrity.
- At JCB, we make our own hydraulic cylinders, cabs, axles, transmissions and engines – all designed to work in perfect harmony for optimum reliability. We now offer a range of robust Rockinger hitches, to maximise the towing potential of our Loadalls across Europe.

To ensure reliability of our JCB DIESELMAX engines, we've tested units for 110,000 hours in 70 different machines across the toughest applications and environments.



To provide long-term protection, we dip every AGRI Loadall cab in electrophoretic alloy before painting it.



A SLICK OPERATION.

FOR AN AGRICULTURAL MACHINE TO PROVIDE MAXIMUM PRODUCTIVITY, IT NEEDS TO BE INTUITIVE AND COMFORTABLE TO OPERATE ACROSS A WIDE VARIETY OF CONDITIONS AND CLIMATES. THE JCB AGRI LOADALL RANGE PROVIDES THE MOST ERGONOMIC WORKING ENVIRONMENT AROUND, WITH FEATURES APLENTY TO HELP KEEP OPERATORS FOCUSED ALL DAY LONG.

Ergonomic controls.

- 1 For ergonomic, fast and precise control, AGRI Loadalls are fitted with a fully proportional single lever servo control system.
- 2 Backlit switches ensure quick and accurate control recognition, even in the dark.
- 3 All operators from novices to experts will find JCB Loadalls easy to use; the cab interior is designed to be intuitive and uncomplicated, with clear instruments and a familiar automotive-style control layout.
- 4 To tailor your Loadall to any driving style, choose the easily adjustable tilting steering column.



An AGRI Loadall's standard-fit tinted cab glass will reflect 30% of the sun's energy for enhanced operator comfort.

Comfort and convenience.

- To keep operators comfortable and focused, our cab offers a uniformed airflow, hot or cold to through 8 different vents giving the operator great comfort from the depths of winter to hot harvesting days. Optional air conditioning makes it even easier to find the perfect cab temperature.
- We now offer front, rear and boom LED worklight options to optimise visibility at night or in other darkened operating areas like outbuildings.
- All-round visibility on an AGRI Loadall is excellent, courtesy of direct glazing and a large roof screen, as well as a low bonnet.
- In addition we have angled our roof bars to ensure maximum visibility when bale stacking at height.
- We've made it possible to close the upper door from outside thanks to an exterior top door slam latch.



SAFETY AND SECURITY.

JCB AGRI LOADALLS ARE EQUIPPED WITH A NUMBER OF STRINGENT SAFETY MEASURES TO HELP GUARD AGAINST ACCIDENTS. THERE'S ALSO A HIGH LEVEL OF SECURITY TECHNOLOGY INSTALLED.

Protecting people.

- 1 Excellent cab access, with three points of contact and ergonomically positioned grabs, handles and foot step.
- 2 Hose burst check valves on the rams prevent collapse if a hose fails.
- 3 The low boom profile and low boom pivot make for superb rear and all round visibility.
- 4 Standard fitment of a reverse alarm to all AGRI Loadalls.
- 5 Adaptive Load Control technology automatically controls hydraulic operation, helping to maintain the longitudinal stability of these machines.



The JCB factory-fit immobiliser system can either be activated by a unique key or an optional keypad PIN mechanism. The system automatically arms itself after a set time following engine shutdown.

Accidental operation is a thing of the past with our operator presence switch; this feature prevents vehicle movement whenever drivers leave their seats.

LESS SERVICING, MORE SERVICE.

THE RIGOURS OF FARMING ARE SUCH THAT A TELEHANDLER NEEDS TO SPEND AS MUCH TIME AS POSSIBLE AT WORK, NOT BEING WORKED ON. SO JCB LOADALLS HAVE LONG SERVICE INTERVALS AND, WHEN MAINTENANCE DOES NEED TO BE CARRIED OUT, IT'S AN EASY AND QUICK PROCESS.

Maintaining productivity.

- 1 All daily checks and greasing can be carried out at ground level; our centralised greasing system makes for quicker and easier servicing.
- 2 You can access an AGRI Loadall's battery easily (and without specialist tools) via a lockable cover that's opened with the ignition key.
- 3 The diesel tank is also easy to get to, and can be filled from ground level. For protection from dirty fuel, there's an integral pre-filter in the filler neck.
- 4 A dry lubricant system means our wear pads are extremely durable, with service intervals of 500 hours.
- 5 Every fluid filter (engine oil, hydraulic oil and fuel) is centrally located for fast, easy servicing. The air filter is easily accessed too, and its double-element design simplifies cleaning.



LIVELINK, WORK SMARTER.

LIVELINK IS AN INNOVATIVE SOFTWARE SYSTEM THAT LETS YOU MANAGE JCB MACHINES REMOTELY – ONLINE, BY EMAIL OR BY MOBILE PHONE. ACCESS EVERYTHING FROM MACHINE ALERTS TO HISTORY INFORMATION, WITH ALL DATA STORED AT A SECURE CENTRE.

Productivity and cost benefits

All LiveLink equipped Loadall machines built are now able to report fuel economy, idle time and engine load data through the LiveLink web portal, helping you reduce your fuel usage, saving you money and improving productivity. Machine location information can help improve efficiency and perhaps even reduce insurance costs.



Maintenance benefits

Manage machine maintenance easily – accurate hours monitoring and service alerts improve maintenance planning, while real-time location data helps you manage your fleet. Critical machine alerts and maintenance history records are also available.



Security benefits

LiveLink's real-time geofencing alerts tell you when machines move out of predetermined zones, and real-time curfew alerts inform you of unauthorised usage. Further benefits include real-time location information, advanced ECU matching (pairs LiveLink with the immobiliser or ECU).



VALUE ADDED.

JCB'S WORLDWIDE CUSTOMER SUPPORT IS FIRST CLASS. WHATEVER YOU NEED AND WHEREVER YOU ARE, WE'LL BE AVAILABLE QUICKLY AND EFFICIENTLY TO HELP MAKE SURE YOUR MACHINERY IS PERFORMING TO ITS FULL POTENTIAL.



1 Our Technical Support Service provides instant access to factory expertise, day or night, while our Finance and Insurance teams are always on hand to provide fast, flexible, competitive quotes.

2 The global network of JCB Parts Centres is another model of efficiency; with 15 regional bases, we can deliver around 95% of all parts anywhere in the world within 24 hours. Our genuine JCB parts are designed to work in perfect harmony with your machine for optimum performance and productivity.

3 JCB Assetcare offers comprehensive extended warranties and service agreements, as well as service-only or repair and maintenance contracts. Irrespective of what you opt for, our maintenance teams around the world charge competitive labour rates, and offer non-obligation quotations as well as fast, efficient insurance repair work.

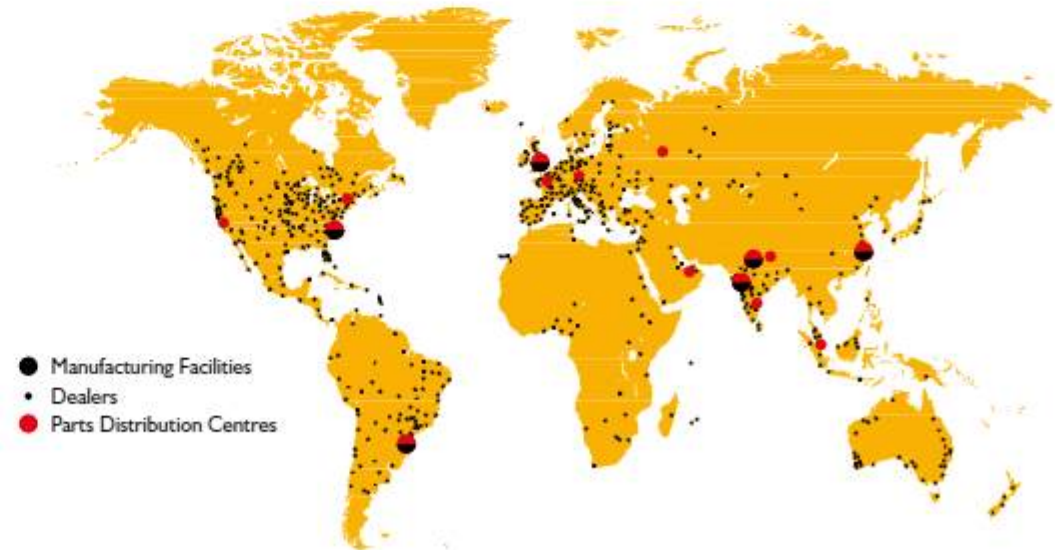

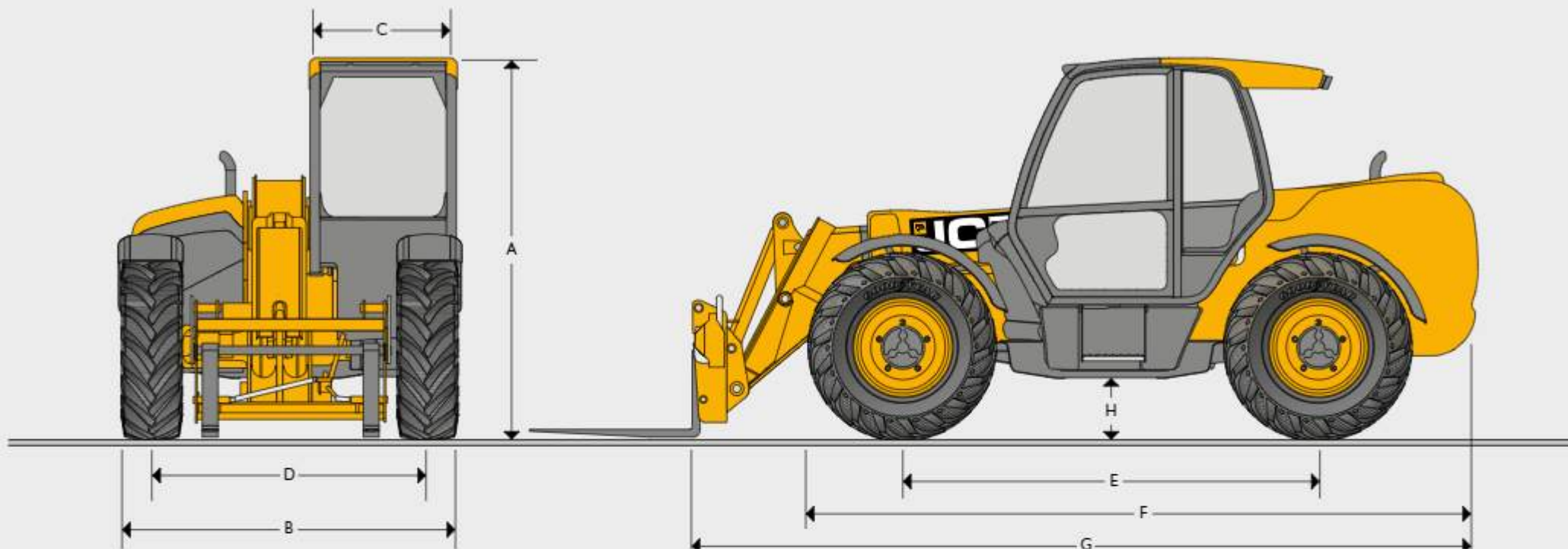

STATIC DIMENSIONS

Machine model		531-70	535-95	536-60	536-70	541-70
A Overall height	m	2.49	2.49	2.49	2.49	2.49
B Overall width (over tyres)*	m	2.29	2.36	2.29	2.29	2.29
C Inside width of cab	m	0.94	0.94	0.94	0.94	0.94
D Front track	m	1.81	1.87	1.81	1.81	1.81
E Wheelbase	m	2.75	2.75	2.75	2.75	2.75
F Overall length to front tyres	m	4.38	4.38	4.03	4.38	4.38
G Overall length to front carriage	m	4.99	4.99	4.55	4.99	4.99
H Ground clearance	m	0.4	0.4	0.4	0.4	0.4
Outside turn radius (over tyres)	m	3.7	3.7	3.7	3.7	3.7
Carriage rollback angle	degrees	42.6	41	42.6	42.6	42.6
Carriage dump angle	degrees	37.5	24	42.5	37.5	37.5
Weight	kg	6900	8020	7200	7800	7800
Tyres		460/70 R24	445/70 R24	460/70 R24	445/70 R24	445/70 R24

Machine shown with optional roof mounted air conditioning fitted on Agri Plus and Agri Super.

*Dependant upon tyre specified.

LIFT PERFORMANCE

Machine model		531-70	535-95	536-60	536-70	541-70
						
Maximum lift capacity	kg	3100	3500	3600	3600	4100
Lift capacity to full height	kg	2400	1600	3600	2500	2500
Lift capacity at full reach	kg	1250	500	1500	1350	1500
Lift height	m	7	9.5	6.2	7	7
Reach at maximum lift height	m	0.48	2.43	0.87	0.48	0.48
Maximum forward reach	m	3.7	6.52	3.3	3.7	3.7
Reach with 1 tonne load	m	3.7	5.08	3.3	3.7	3.7
Placing height	m	6.3	8.78	5.42	6.3	6.3

Complies with stability test EN 1459 Annex B.

ENGINE		JCB DIESELMAX STAGE V	
Machine model		531-70 / 535-95 / 536-60 / 536-70 / 541-70	531-70 / 535-95 / 536-60 / 536-70 / 541-70
Manufacturer		JCB	JCB
Displacement	ltr	4.4	4.4 / 4.8
No. of cylinders		4	4
Bore size	mm	103	103 / 106
Stroke	mm	132	132 / 135
Aspiration		Turbocharged cooled	Turbocharged cooled
Power rating			
Power @ 2200rpm	kW (hp)	74.2 (100)	97 (130) / 108 (145)
Torque rating			
Torque @ 1300rpm	Nm	440	-
Torque @ 1500rpm	Nm	-	532/550

TRANSMISSION	<p>Agri / Agri Plus: JCB powershift transmission incorporating torque converter, bevel box and a 4-speed powershift gearbox in one resiliently mounted unit. Manual gear shift incorporated onto the single lever joystick with 4 forward and 4 reverse powershift gears. Travel speed 33kph. Permanent 4-wheel drive. Switchable transmission disconnect on brake pedal. Agri Super: JCB 6-speed transmission incorporating torque converter, bevel box and 6-speed powershift gearbox with TorqueLock in 5th and 6th gear in one resiliently mounted unit. 2 operating modes: Manual and Auto. Travel speed 40kph. Electrical 2/4 wheel drive select. Gear shift on single lever joystick. Auto selection between 4th and 6th gear in auto mode. Switchable transmission disconnect on brake pedal. Front and rear drive axles: JCB epicyclic hub reduction drive/steer axles with Max-Trac torque proportioning differential.</p> <p>Front and rear drive axles: JCB epicyclic hub reduction drive/steer axles with Max-Trac torque proportioning differentials.</p>
BRAKES	<p>Service brakes: Hydraulically activated, self-adjusting, oil-immersed in-board high back-off multi-disc type on front axle.</p> <p>Parking brake: Hand-operated disc brake on output of gearbox (97kW/100hp, 108kW/145hp - oil immersed disc type).</p>
BOOM AND CARRIAGE	Boom is manufactured from high tensile steel. JCB Q-fit self-levelling carriage with lever operated pin locking accepts pallet forks and a wide range of attachments.
STEERING	Hydrostatic power steering with power track rods on both axles.

DELUXE CAB	<p>Quiet, safe and comfortable cab conforms to ROPS ISO 3471 and FOPS ISO 3449. Tinted glass all round with laminated front and roof screen. Roof bars, front, rear and roof screen wash/wipe and heater/screen demister. Opening rear window. Audio-visual warning system for coolant temperature, water in fuel, engine oil pressure, air cleaner, battery charge, transmission oil temperature and pressure. Hourmeter and road speed indicator. Engine temperature, fuel gauge and dock. Adjustable steer column with stalk bar powershift change and forward reverse shuttle. Throttle and brake pedal floor mounted. Adjustable deluxe suspension seat with adjacent park brake. Automatic eye level audio-visual load moment indicator warning system receiving a signal from a load sensor on the rear axle. This system continuously monitors the machine's forward stability and leaves the operator in control at all times.</p> <p>Hydraulic controls:</p> <p>AgriPlus/Super: Cab mounted single lever servo joystick, incorporating forward/neutral/reverse, with progressive extend/retract and auxiliary incorporating constant flow facility.</p>
OPTIONS AND ACCESSORIES	Options: Front and rear working lights, rotating flashing beacon, fire extinguisher, radial industrial tyres, electrical 2/4WD select, limited slip differential in front axle, windscreen and roof guard, air suspension seat, roof and front screen blind, radio kit, air conditioning, reversing fan, 2 speed and intermittent front wash/wipe, high flow auxiliary, smoothside system, towing facility with trailer lighting package, carriage options available – contact your local dealer. Clean air kit.

OPTIONS			
Model	531-70, 536-60, 536-70, 541-70	535-95	541-70
Sub model	Agri / DS, Agri Plus / DS + Agri Super	Agri / DS, Agri Plus / DS + Agri Super	BIOMASTER
Standard features			
Rockinger hitch range (6 types)	<input type="radio"/>	<input type="radio"/>	<input type="radio"/>
LED work lights (front and rear)	<input type="radio"/>	<input type="radio"/>	<input checked="" type="radio"/>
LED boom work lights (boom)	<input type="radio"/>	<input type="radio"/>	<input checked="" type="radio"/>
BIOMASTER			
Boom nose cover	<input type="radio"/>	<input type="radio"/>	<input checked="" type="radio"/>
Airconditioning	<input type="radio"/>	<input type="radio"/>	<input checked="" type="radio"/>
Clean air kit	<input type="radio"/>	<input type="radio"/>	<input checked="" type="radio"/>
Remote greasing	<input type="radio"/>	<input type="radio"/>	<input checked="" type="radio"/>
<input checked="" type="radio"/> Standard <input type="radio"/> Option			

HYDRAULICS							
		531-70		535-95		536-60	
Model		Agri	Agri Plus / Agri Super	Agri	Agri Plus / Agri Super	Agri	Agri Plus / Agri Super
Operating system pressure	bar	241	241	241	241	260	260
Main hydraulics	l/min	140	140	140	140	140	140
Pump		Variable	Variable	Variable	Variable	Variable	Variable
Hydraulic cycle times		Seconds	Seconds	Seconds	Seconds	Seconds	Seconds
Lift		5.3	5.1	6	5.9	6.5	6.2
Lower		5	4.5	5.2	4.9	5.0	5.0
Extend		6.1	5.1	12.3	10.0	5.5	5.5
Retract		5.5	5.3	11.4	9.5	4.5	4.5
Bucket dump		3.2	3.2	2.0	2.0	3.2	2.8
Bucket crowd		2.5	2.3	2.4	2.3	2.5	2.2

HYDRAULICS							
		536-70		541-70			
Model		Agri	Agri Plus / Agri Super	Agri	Agri Plus / Agri Super		
Operating system pressure	bar	260	260	260	260		
Main hydraulics	l/min	140	140	140	140		
Pump		Variable	Variable	Variable	Variable		
Hydraulic cycle times		Seconds	Seconds	Seconds	Seconds		
Lift		6	5.8	6	5.8		
Lower		7.4	6.6	7.4	6.6		
Extend		7.7	5.7	7.7	5.7		
Retract		5.4	5.3	5.4	5.3		
Bucket dump		3.2	3.2	3.2	3.2		
Bucket crowd		2.6	2.6	2.6	2.6		

SERVICE CAPACITIES			
Fuel tank	litres	146	
Hydraulic tank	litres	113	
Coolant	litres	23	
Engine oil sump	litres	14	

ELECTRICAL SYSTEM			
System voltage	Volt	12	
Alternator	Amp/hour	95	
Battery capacity	Amp/hour	110	



ONE COMPANY, OVER 300 MACHINES.

Your nearest JCB dealer

AGRI LOADALL 531-70/535-95/536-60/536-70/541-70

Gross power: 74.2kW/100hp – 108kW/145hp Lift capacity: 3,100kg – 4,100kg Lift height: 6,200mm – 9,500mm

JCB Agriculture, Rocester, Staffordshire ST14 5JP.
 Tel: +44 (0)1889 590312 Email: salesinfo@jcb.com
 Download the very latest information on this product range at: www.jcb.com

[facebook.com/JCBAg](https://www.facebook.com/JCBAg)
 [@JCBAgriculture](https://twitter.com/JCBAgriculture)
[youtube.com/JCBAgriculture](https://www.youtube.com/JCBAgriculture)

©2014 JCB Sales. All rights reserved. No part of this publication may be reproduced, stored in a retrieval system, or transmitted in any form or by any other means, electronic, mechanical, photocopying or otherwise, without prior permission from JCB Sales. All references in this publication to operating weights, sizes, capacities and other performance measurements are provided for guidance only and may vary dependent upon the exact specification of machine. They should not therefore be relied upon in relation to suitability for a particular application. Guidance and advice should always be sought from your JCB Dealer. JCB reserves the right to change specifications without notice. Illustrations and specification shown may include optional equipment and accessories. All images are correct at time of print. The JCB logo is a registered trademark of J.C. Bamford Excavators Ltd.

