

weSLICE 1000

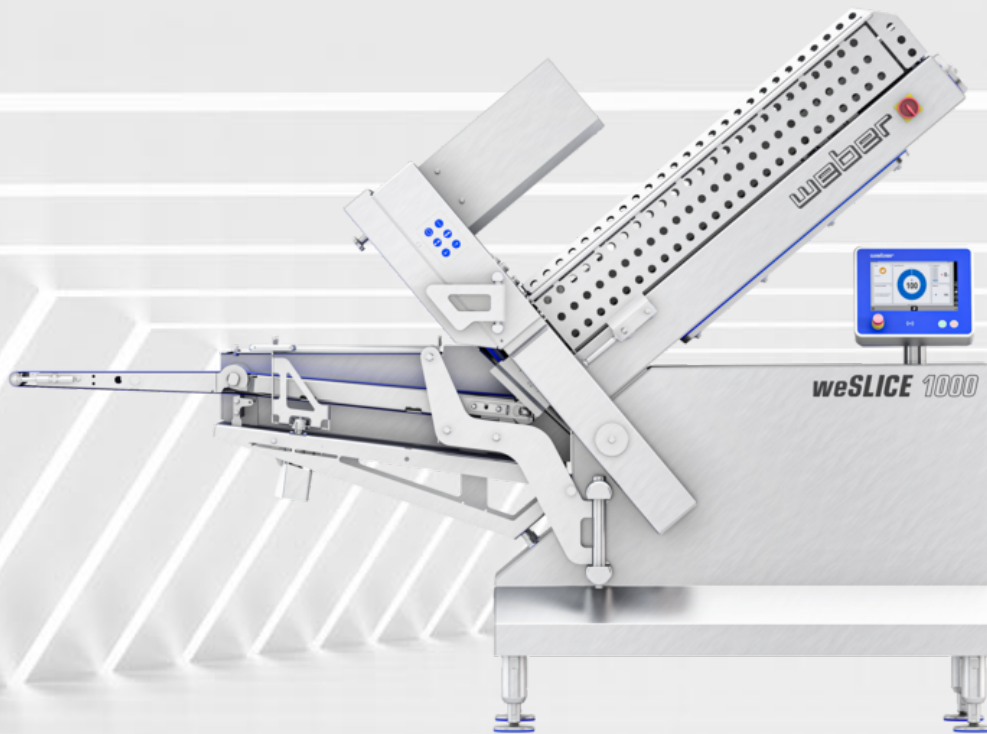

Product details

- Flexible slicer for small batches
- Maximum slicing and processing quality
- Perfect solution for food producers in the craft sector
- Available as movable version

[View online](#)



Advantages

 Circular blade

 Weber Hygiene Design

 Quick set-up time

 Manual loading

Weber Slicer weSLICE 1000: a compact slicer with power!

The Weber weSLICE 1000: a compact slicer with power! This slicer is designed for your entry into the world of industrial sliced food production. At Weber, we are committed to providing our customers with perfect solutions across all performance levels. With its sleek and streamlined design, the weSLICE 1000 is ideal for food producers in the craft sector or for small-batch production. Despite being Weber's most compact slicer, it does not compromise on slicing and processing quality, or perfect portion placement.

The circular blade slicer processes products with a length of up to 1,000 mm at a slicing performance of 400 slices per minute. The weSLICE 1000 is loaded manually, and sliced portions are transported via the integrated universal belt conveyor. For added convenience, the weSLICE 1000 is optionally available with wheels for easy mobility within the production area. Thanks to its lubricated construction and the renowned Weber Hygiene Design, the slicer is highly maintenance-friendly and hygienic. To enhance user-friendliness, the weSLICE 1000 comes equipped with a standard 12" touch display featuring a simple and intuitive user interface.

Presentation



Stacked



Staggered Stack



Shingled-stack



Shingled



Endless-shingled



Technical Data weSLICE 1000

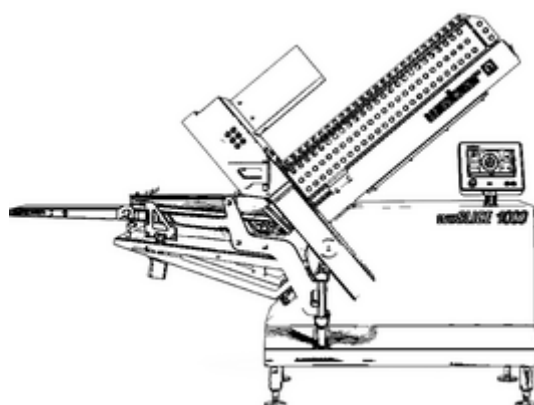

Height (mm)	2065
Width (mm)	960
Length (mm)	2348
Weight (kg)	990
Product throat height (mm)	125/135/150
Product throat width (mm)	250
Product length (mm)	1000
Slicing system	Circular blade
Slicing thickness (mm)	0,5-50
Loading (automatic/manual)	Manually
Circular blade cutting speed (rpm)	max. 400

Weber means: service across the board.



Weber Academy.

Maximize line performance through professional training courses.

At the Weber Headquarter in Breidenbach, Germany, we have our own training center, the Weber Academy. Being a provider of complete line solutions, we offer training courses for your Weber Line, tailored precisely to your needs. In doing so, our focus is always on increasing efficiency and optimizing profit in your company.



Weber Guardian.

A safe plan for your production.

Only those who listen can understand. And those who understand can act. With our Weber Guardian program, we harmonize people, machines, and processes to get the most out of production. From preventive maintenance and inspection through targeted personnel development to production support and optimization.



Weber Portal.

Networked thinking, handling together.

You will find everything about your Weber equipment bundled in your personal Weber Portal. Compact, individual and interactive. From your customer profile and that of your machines to e-learning on your setup as well as convenient spare parts ordering and service offers. Are you already registered?

We are looking forward to your message.



Filip Oršić

Managing Director

weber.SEE@weberweb.com

Weber Food Technology GmbH

Günther-Weber-Straße 3 | 35236 Breidenbach | Germany

Phone: +49 6465 918 - 0 | Fax: +49 6465 918 - 11 00

info@weberweb.com | www.weberweb.com

weber

Legal notice

This document was generated automatically on 03/09/2024. All information is non-binding. We reserve the right to make changes in the interest of technical progress. For the latest information on this product, please visit:

<https://www.weberweb.com/portfolio/slicer/weslice-1000/>