

# AK RON 1300

AUTOMATIC SINGLE-SIDED  
EDGEBANDING MACHINES



 **BIESSE**

# MODEST INVESTMENT, HIGH RANGE TECHNOLOGY

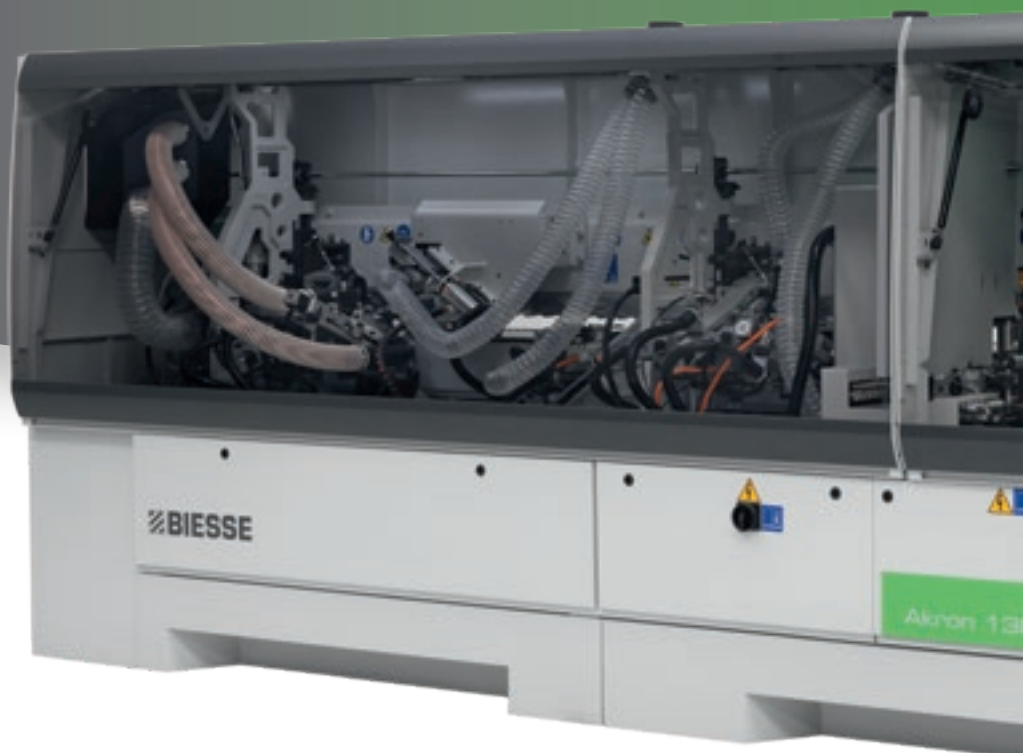

WATCH THE VIDEO

## THE MARKET EXPECTS

a change in manufacturing processes that enables companies to accept the **largest possible number of orders**. This is coupled with the need to maintain high quality standards whilst offering product customisation with quick and defined delivery times, as well as responding to the needs of highly creative designers.

## BIESSE MEETS

these requirements with **technological solutions** that highlight and support technical expertise as well as process and material knowledge. **Akron 1300** is a range of automatic single-sided edgebanding machines purposely created for craftsmen and companies looking for user-friendly, customised production, flexible solutions in a limited space.



## **AKRON** 1300

- ✓ BUILT ACCORDING TO THE SPECIFIC PRODUCTION REQUIREMENTS
- ✓ HIGH FINISH QUALITY
- ✓ MAXIMUM WORKING PRECISION
- ✓ TECHNOLOGY AT THE SERVICE OF THE USER

# NEW DESIGN



More spacious new design, optimised for greater practicality.

Vertical LED bar with different colours to understand the machine status at any moment.



Sliding chip collection containers to keep the workplace clean at all times (opt).

# HIGH FINISH QUALITY



Perfect finish, due to the 2-motor Pre-milling unit with automatic intervention.

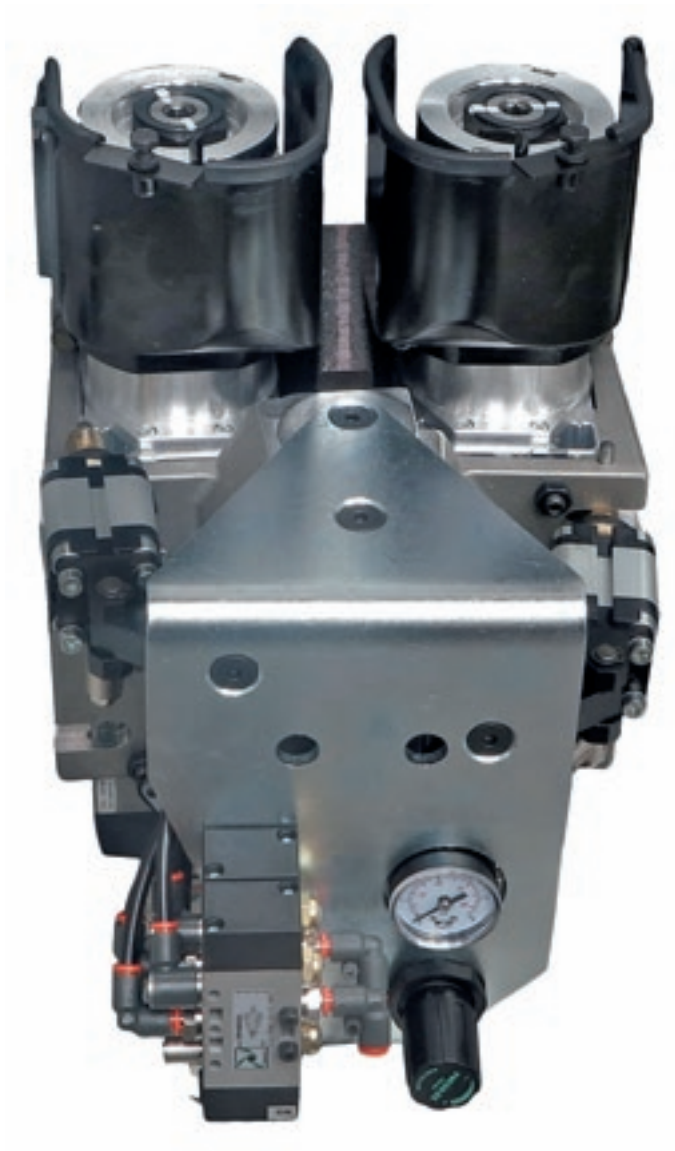

As standard, Akron uses only the electrospindles of the exclusive Rotax range on all the machines. These are electrospindles of the highest quality, designed and made by HSD (a leader in this sector); they guarantee optimum power, compact dimensions, and extremely high finishing standards.



The **Pre-milling Autoset** device for the automatic centring of the tool on the panel improves quality whilst reducing set-up times.



# GROUND-BREAKING TECHNOLOGY, FOR TOP PERFORMANCE

Our specific Research & Development team creates pioneering solutions to meet the market requirements and offer cutting edge technology that's reliable and guarantees first class results.



**Gluing unit** for the automatic application of edging in rolls or strips, from 0.4 to 5 mm.

# HIGH GLOSS EDGES

## FLAWLESS EDGES

Highly technological solutions for perfect machining of the most delicate surfaces as well as maximised productivity.

The End Trimmer assembled on an Akron 1300 is the most competitive and high performance solution of its type. High range technology, ideal for delicate and High Gloss surfaces due to the copying and tracing system that doesn't involve any form of rubbing or scraping. It ensures an extremely reduced gap between panels (unique on the market), to increase productivity.



# MANY SOLUTIONS FOR OPTIMAL MANAGEMENT OF GLUE



## Glue pot

The glue pot is equipped with a pre-copying system to prevent direct contact between the roller and the panel, preserving the surface quality of the machined panel whilst allowing for a smooth and even application of glue, without wear to the glue pot.



## New hybrid glue head for using EVA and PUR

- ✔ One single glue head that can work with both EVA and PUR in granules
- ✔ High flexibility thanks to the automatic system that drains the glue from below
- ✔ Automatic roller cleaning cycle on the basis of the panel length
- ✔ Glue level sensor, Pop up alert in the screen when the glue is finishing



## Pre-melter for EVA glue

To meet all the priority machining needs:

- ✔ More glue available
- ✔ Easy control of the glue level



# MAXIMUM MACHINING FLEXIBILITY AND EFFICIENCY

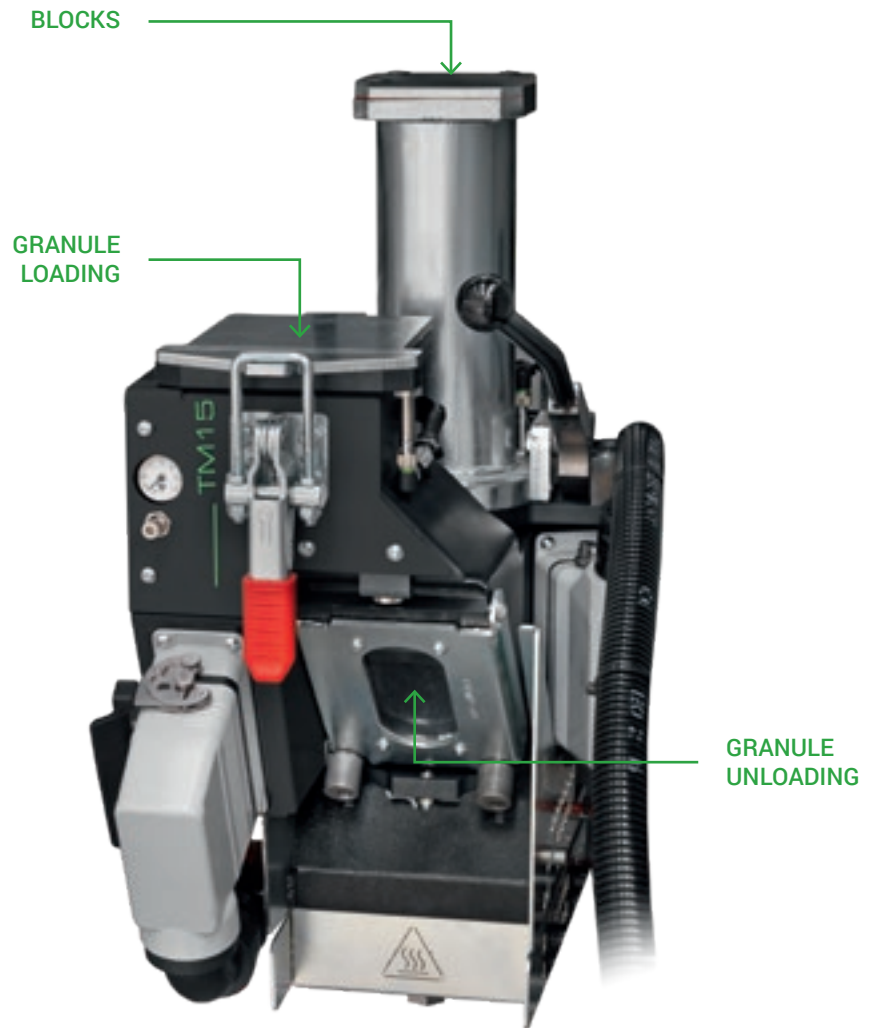

## TM15 Hybrid Top Melt pre-melter

New hybrid system for melting on-demand glue from above:

- ✔ Hybrid pre-melter for working PUR or EVA glue, to meet every possible need
- ✔ High flexibility thanks to the possibility to use glue either in granules or in small cartridges
- ✔ Hermetically sealed system for a long glue lifespan
- ✔ Quick and easy maintenance procedures that require no special skills of the operator and can be carried out following the dedicated tutorial videos

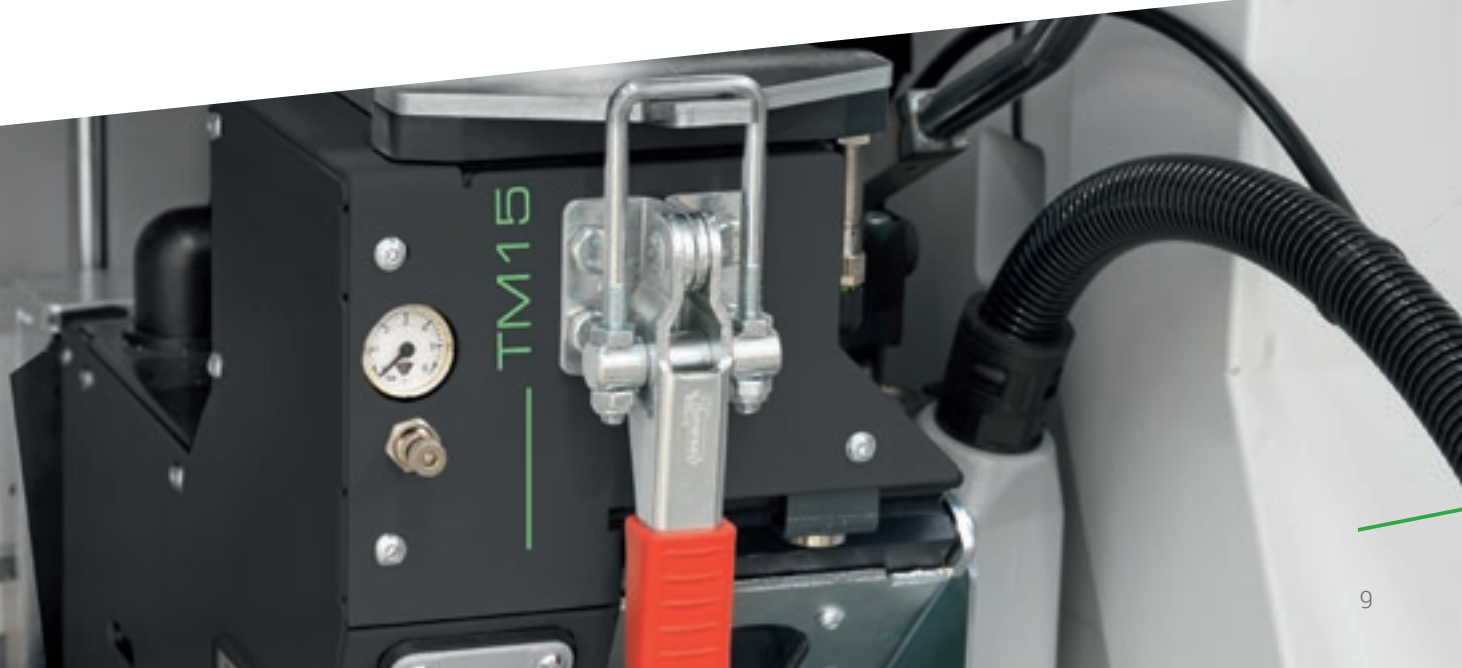

# AIR FORCE SYSTEM

## INVISIBLE EDGEBOARDING

**No joints and no glue line, in perfect harmony with the panel.**

AirForce System, available on Biesse edgebanding machines, is based on the physical principle of convection. By using a compressed hot air system, the edge bonds perfectly with the panel guaranteeing resistance to water and heat and an excellent long lasting quality finish.



# MAXIMUM WORKING PRECISION

Unprecedented product quality and reduced machining times, thanks to technological solutions created for the specific day-to-day work.

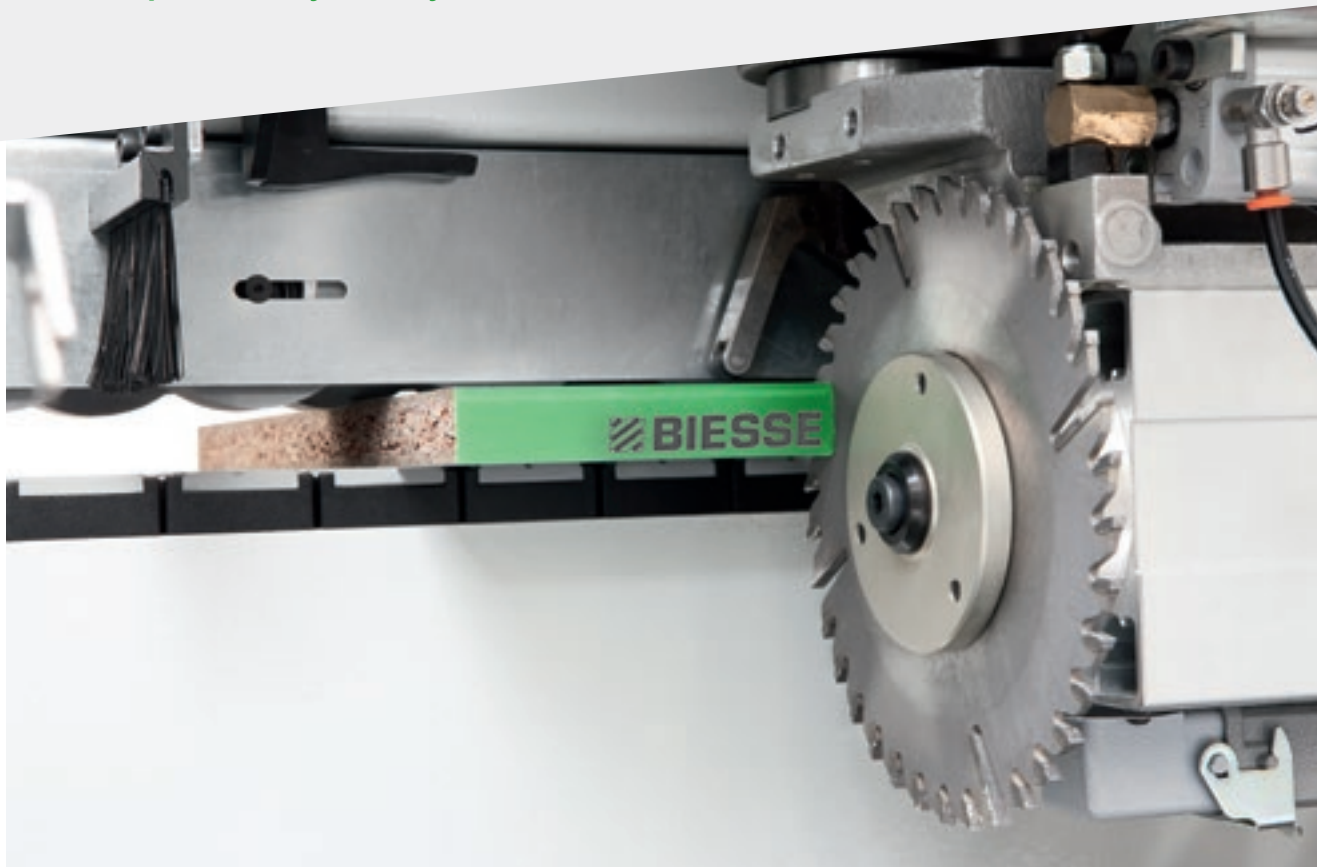

Reliability and cutting accuracy, due to the End Trimmer that removes excess edge at the front and rear of the panel. The Flex system, which is standard on the end trim automatically adjusts the excess edge whether the corner rounding unit is or is not being used.

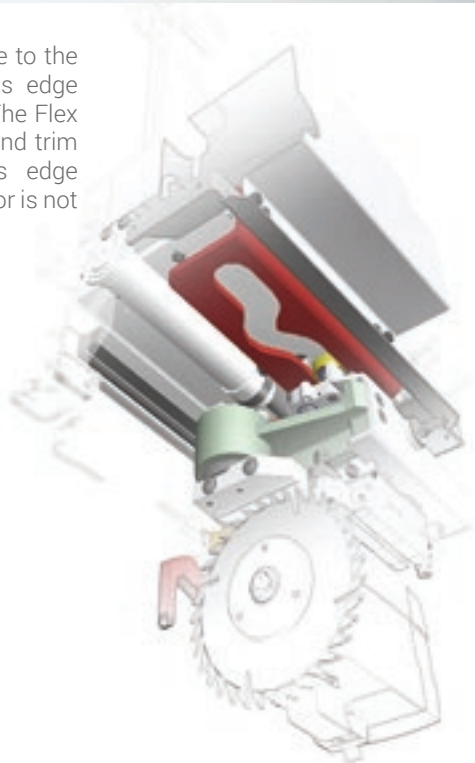

Optimal quality, accuracy and reliability with the new DESMO linear edge trimming unit, with "tracking" copying system.

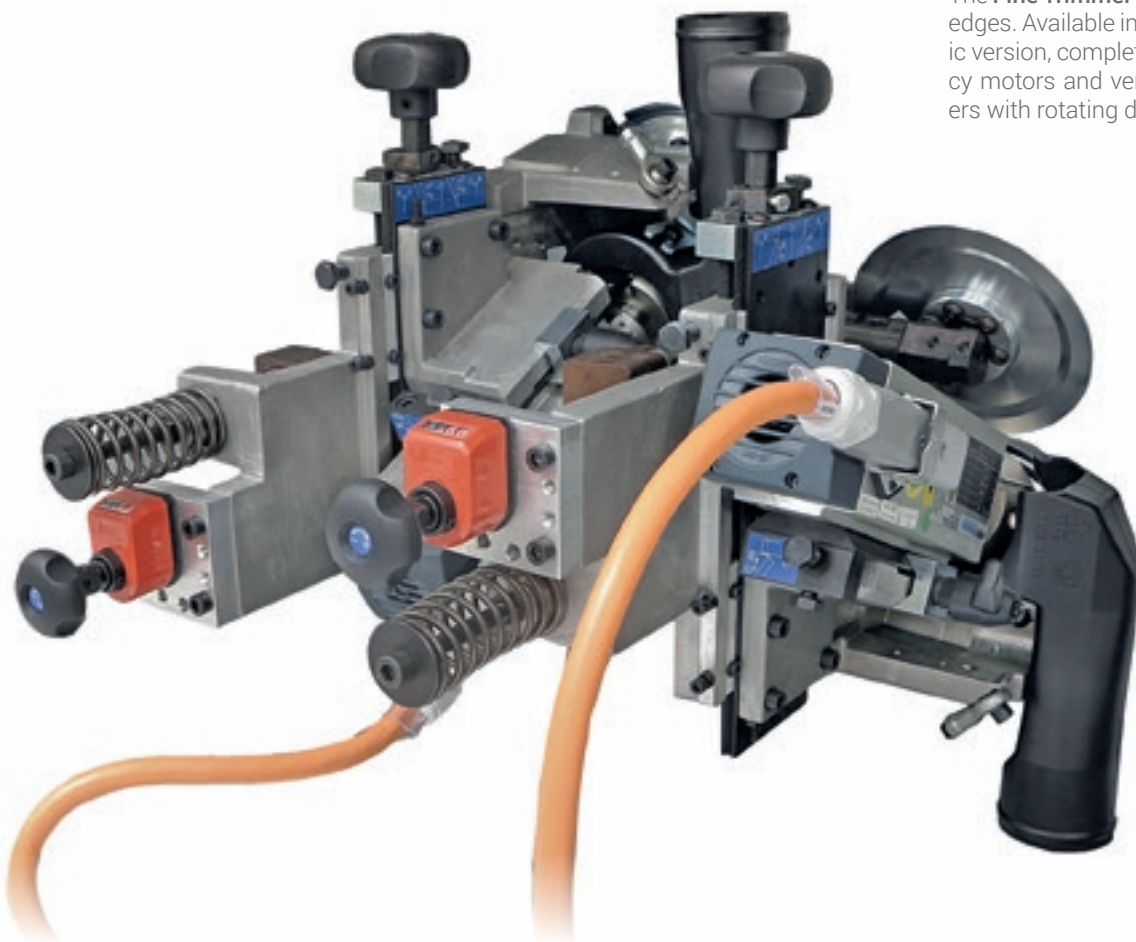

The **Fine Trimmer** for the top and bottom edges. Available in a manual or automatic version, complete with 2 high-frequency motors and vertical/ horizontal copiers with rotating disc.

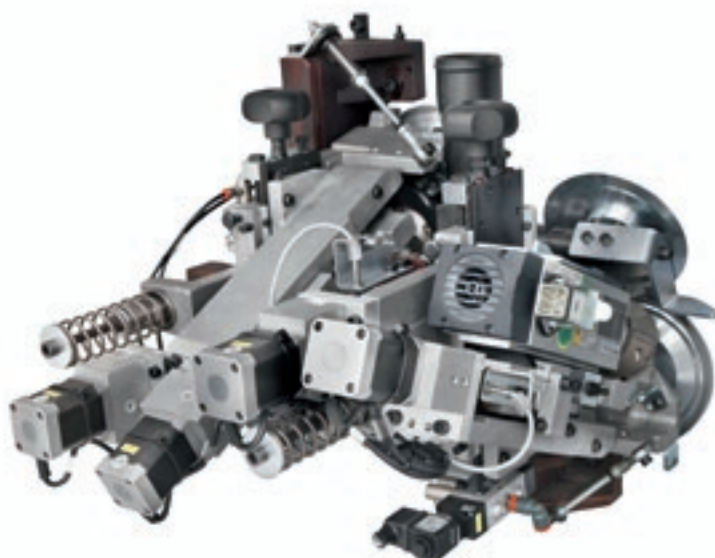

**Stepper Motor**

The working units can all be equipped with automatic axis for the machining changeover. Fitted with motors with an axis positioning tolerance of 0.01 mm, they ensure optimum machining accuracy.

# HIGH QUALITY PRODUCTS

The multipurpose Corner rounding tool with two motors is used to apply radiusing not only on the front and rear edges but also on the upper and lower parts of the panel.

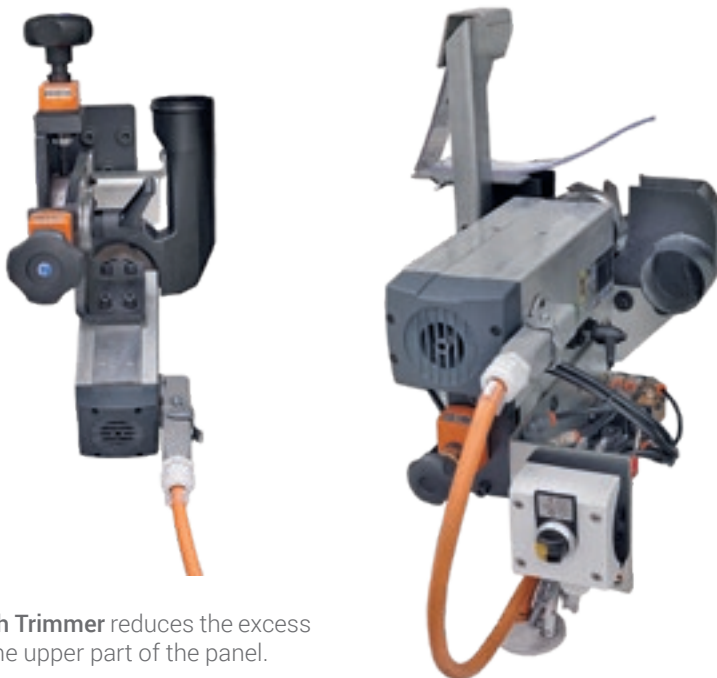
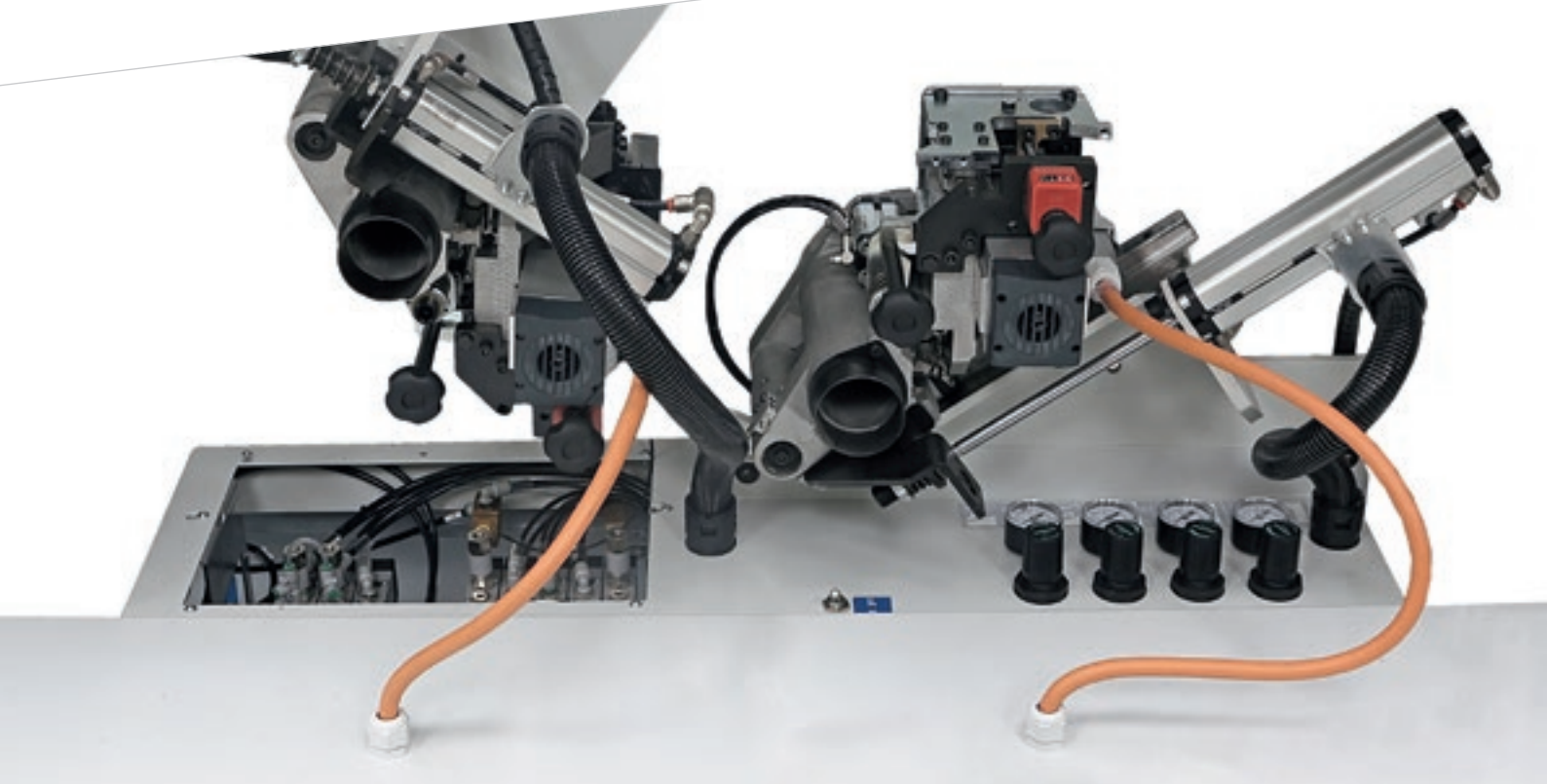

The **Grooving Unit** creates grooves and performs milling operations on the underside of the panel.

The **Rough Trimmer** reduces the excess edge on the upper part of the panel.



The **Edge scraper** eliminates imperfections resulting from previous machining operations on the top and bottom of the edge.

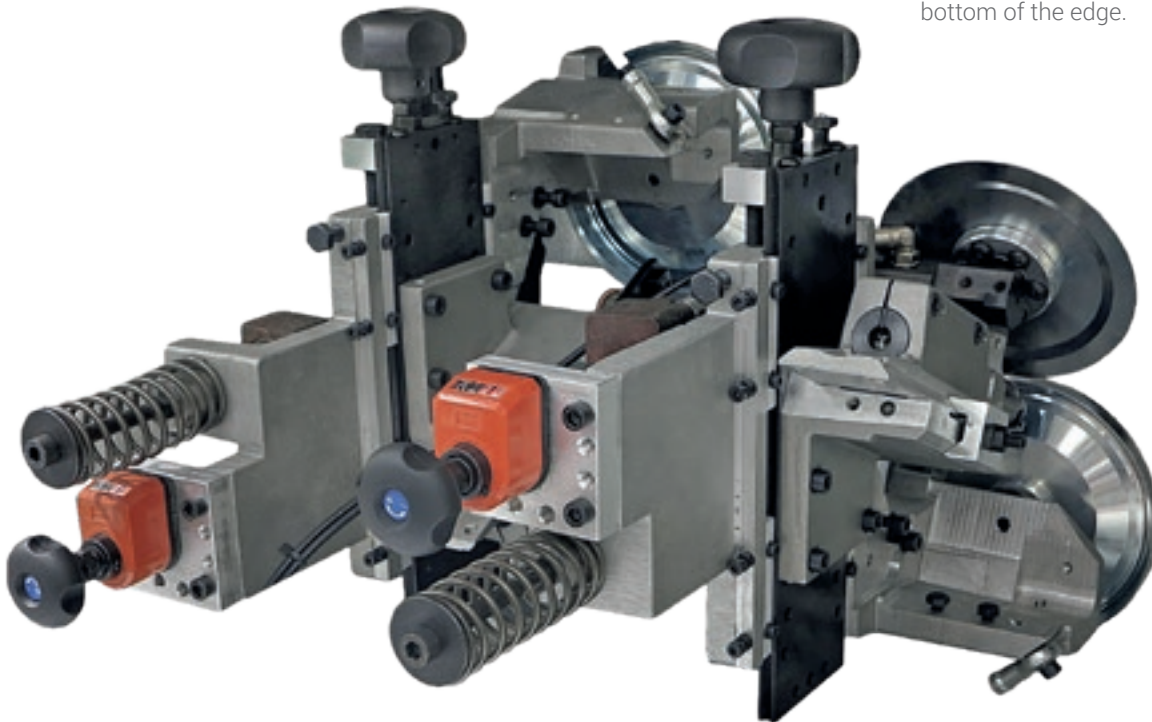

NC axes also available on the Edge Scraper, for excellent machining precision.

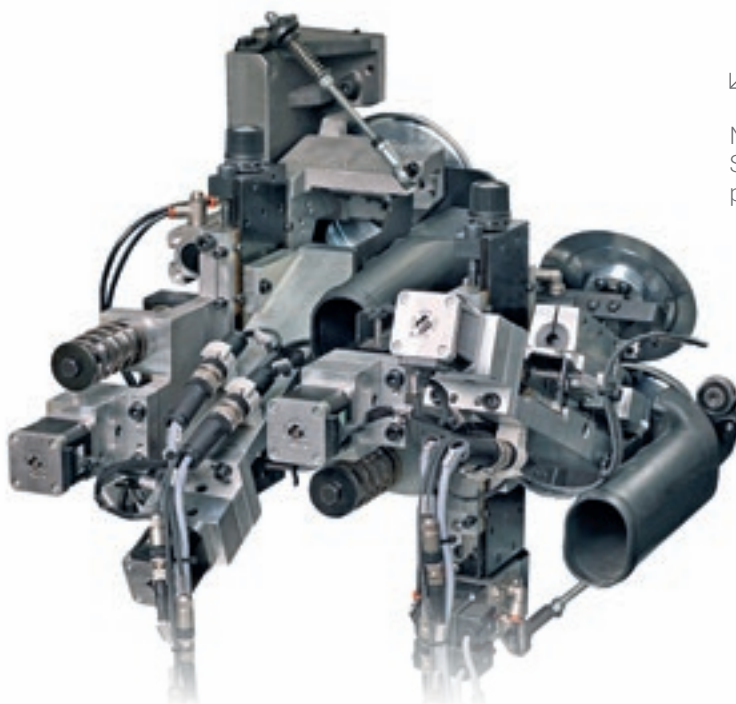

# IDENTITY



## PRACTICAL DESIGN

**An innovative yet simple design is the hallmark of Biesse's distinctive identity.**

The transparent polycarbonate reinforced protection door is designed to guarantee maximum visibility for the operator. Fitted with 5-colour LEDs indicating machine status, it ensures that processing phases can be easily monitored.





# PERFECT FINISH ON EVERY TYPE OF MACHINING OPERATION



The **Glue Scraper** removes excess glue from the top and underside of the panel. This is the only model on the market fitted with 4 pneumatic cylinders for a top quality finish.



**Buffing unit** for cleaning and polishing the edge and panel.

# TECHNOLOGY AT THE SERVICE OF THE USER



Advanced Statistics for monitoring productivity:

- ✔ Different types of charts available to understand and improve edgeworking machine performance
- ✔ Sub-division of the production statistics on the basis of the batch or the time gap
- ✔ Mobile app for keeping in contact with the machine status at all times



## New SMART TOUCH 23" control

Simple, user friendly programming thanks to the touchscreen control panel.

# TECHNICAL SPECIFICATIONS



		L
Akron 1320	mm/inch	4007/158
Akron 1330	mm/inch	5060/199

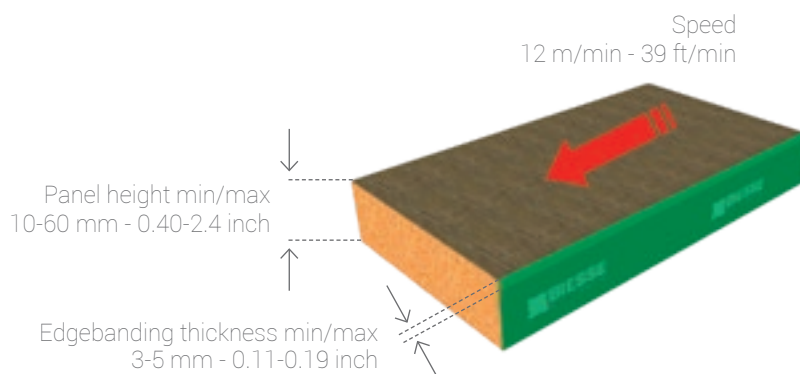

The technical specifications and drawings are non-binding. Some photos may show machines equipped with optional features. Biesse Spa reserves the right to carry out modifications without prior notice.

Weighted surface noise level A (Lp<sub>fA</sub>) 79,66 dB (A). Weighted noise level A (L<sub>wA</sub>) 98,44 dB (A). With AFS gluing device: Weighted surface noise level A (Lp<sub>fA</sub>) 81,95 dB (A). Weighted noise level A (L<sub>wA</sub>) 100,72 dB (A). Uncertainty of measurement K = 4 dB (A).

The measurement was carried out in compliance with UNI EN ISO 18217, UNI EN ISO 3746, UNI EN ISO 11202 and subsequent modifications. The noise levels shown are emission levels and do not necessarily correspond to safe operation levels. Even though there is a relation between emission levels and exposure levels, this cannot be used reliably to establish whether or not further precautions are necessary. The factors determining the actual noise levels to which the operating personnel are exposed include the length of exposure, the characteristics of the work environment, other emission sources (e.g. the number of machines and machining operations nearby). At any rate, the above information allows the operator to better evaluate dangers and risks.

# AVAILABLE CONFIGURATIONS

## Akron 1320

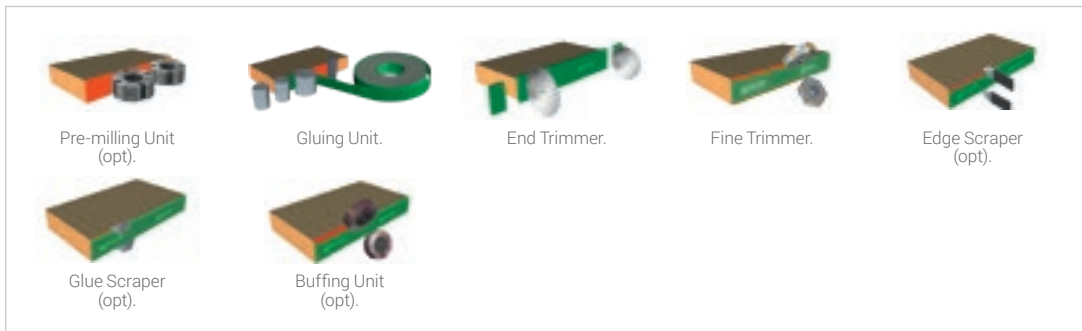

## Akron 1330 - A

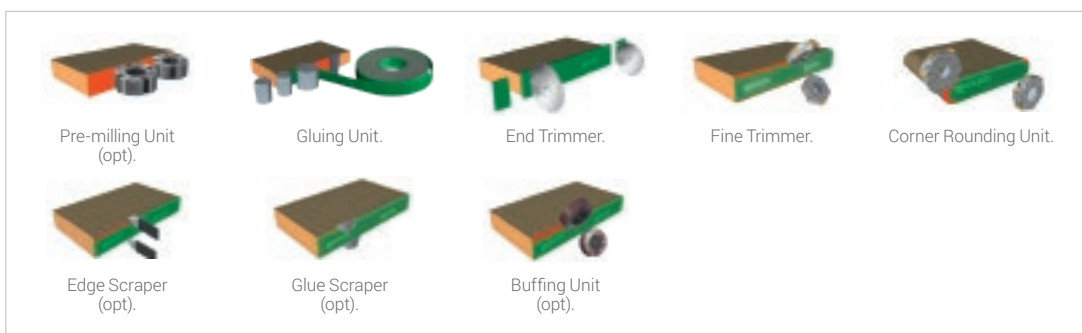

## Akron 1330 - B

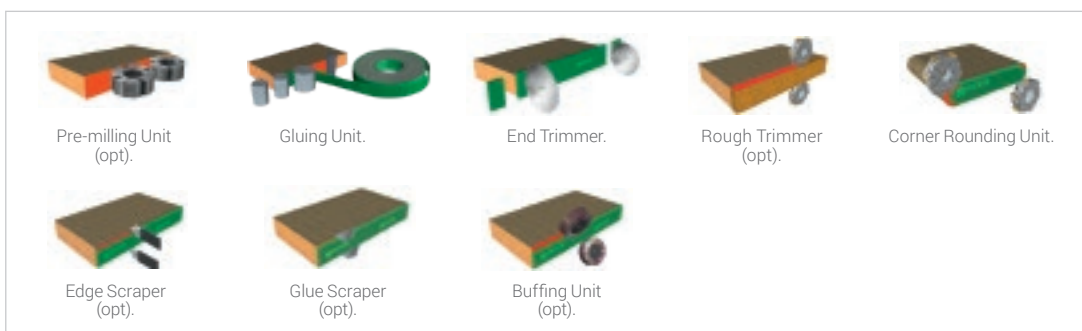

## Akron 1330 - C

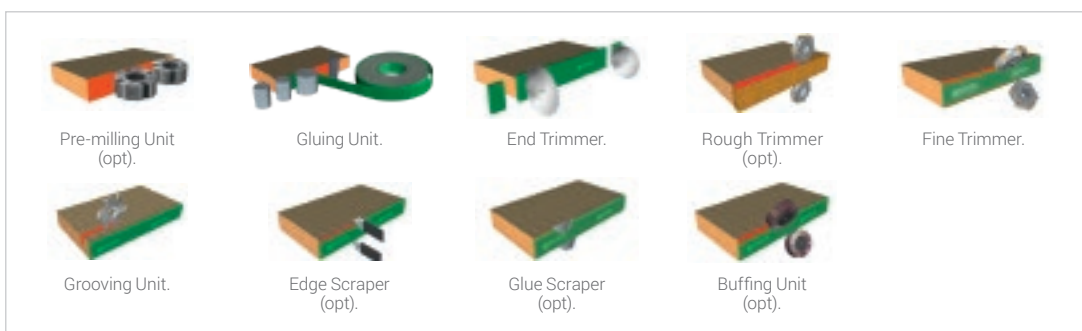

# SOPHIA

GREATER VALUE FROM MACHINES



SOPHIA is the IoT platform created by Biesse in collaboration with Accenture which enables its customers to access a wide range of services to streamline and rationalise their work management processes.

It allows alerts and indicators to be sent to the customer in real time, in relation to production, the machines used and the type of process carried out. These are detailed instructions for more efficient use of the machine.

□ **10% CUT IN COSTS**

□ **50% REDUCTION  
IN MACHINE DOWNTIME**

□ **10% INCREASE  
IN PRODUCTIVITY**

□ **80% REDUCTION IN PROBLEM  
DIAGNOSTICS TIME**

**SOPHIA TAKES THE INTERACTION BETWEEN  
CUSTOMER AND SERVICE TO A HIGHER LEVEL.**

**iOT**  
SOPHIA

IoT - SOPHIA provides a comprehensive overview of the specific machine performance features, with remote diagnostics, machine stoppage analysis and fault prevention. The service includes a continuous connection with the control centre, the option of calling for assistance from within the customer app (such calls are managed as priorities), and an inspection visit for diagnostic and performance testing within the warranty period. Through SOPHIA, the customer receives priority technical assistance.

**PARTS**  
SOPHIA

PARTS SOPHIA is the easy new, user-friendly and personalised tool for ordering Biesse spare parts. The portal offers customers, dealers and branches the chance to navigate within a personalised account, consult the constantly updated documentation of the machines purchased, and create a spare parts purchase basket indicating the real time availability in the warehouse and the relative price list. In addition, the progress of the order can be monitored at all times.

 **BIESSE**

in collaboration with  **accenture**

# CUSTOMER CARE IS WHO WE ARE

**SERVICES** is a new experience for our customers, to offer not just excellent technology but the added value of an increasingly direct connection with the company, the professionals who work there and the experience they embody.



## **ADVANCED DIAGNOSTICS**

Digital channels for remote interaction online 24/7. Always ready to intervene on-site seven days a week.



## **A WORLDWIDE NETWORK**

39 branch offices, over 300 certified agents, retailers in 120 countries, and spare parts warehouses in America, Europe and the Far East.



## **SPARE PARTS AVAILABLE IMMEDIATELY**

Identification, shipping and delivery of spare parts for every need.



## **EVOLVED TRAINING OPPORTUNITIES**

Lots of on-site, online and classroom training modules for personalised growth.



## **VALUABLE SERVICES**

A wide range of services and software packages to help our customers achieve continuous improvements in performance.



## AN EXCELLENT LEVEL OF SERVICE

**+550**

HIGHLY SPECIALISED  
TECHNICIANS AROUND  
THE WORLD, READY TO HELP  
CUSTOMERS WITH EVERY  
NEED

**90%**

OF MACHINE DOWN CASES  
WITH RESPONSE TIME  
UNDER 1 HOUR

**+100**

EXPERTS IN DIRECT  
CONTACT THROUGH  
REMOTE CONNECTIONS  
AND TELESERVICE

**92%**

OF SPARE PARTS ORDERS  
FOR MACHINE DOWNTIME  
PROCESSED WITHIN 24  
HOURS

**+50.000**

ITEMS IN STOCK IN THE  
SPARE PARTS WAREHOUSES

**+5.000**

PREVENTIVE MAINTENANCE  
VISITS

**80%**

OF SUPPORT REQUESTS  
SOLVED ONLINE

**96%**

OF SPARE PARTS ORDERS  
DELIVERED IN FULL ON TIME

**88%**

OF CASES SOLVED WITH  
THE FIRST ON-SITE VISIT

# MADE WITH BIESSSE

## LE BOONE INTERNATIONAL TOP PRODUCTION WITH INTEGRATION AND AUTOMATION

Le Boone International was founded in 1950 by Jan Van Hecke, and has since become a worldwide point of reference in the furnishing sector.

Over the last thirty years, the company has specialised in the design and production of furniture items that optimise the space in the rooms where they're used, from the home to the workplace.

Despite its growth within the market, the company has maintained its production site in Poperinge, Belgium.

"Our market includes various target groups, from people looking for space to those who want to transform it and those who want to live one single area of the home in a multi-purpose way" explains Jan Van Hecke. Le Boone International was set up in a period when house prices were growing all the time: "with the rooms getting smaller, I glimpsed an opportunity. Thirty years ago, I started

creating solutions for safeguarding space, fitting out small rooms with furniture items that had a dual function so the room could be a living room by day and a bedroom at night" says Van Hecke.

The market of Le Boone International developed enormously within a short space of time, and that's why the company soon began to feel the need for machinery that would help speed up the production process so that the many market requests could be met. It decided straight away to invest, purchasing a whole Biesse line that now allows it to greatly reduce production and shipment times.

"After thoroughly analysing the market and evaluating the various solutions, we turned to Biesse. We received substantial technical support during the initial phase of choosing the product, discovering the multitude of possibilities in the huge Biesse range. Six months ago, we opted for a complete solu-

tion with a number of machines that work simultaneously in a line. "First of all", continues Jan Van Hecke, "the Brema Eko 2.1, a vertical boring machine for real time panel machining, the Stream A lateral edgebanding machine, and the Selco WN6 - a panel saw that stands out from its competitors for its amazing flexibility. The extent of the range, the flexibility of the products and the integration of technologies are the factors that have confirmed the efficacy and validity of our choice. For us, this has meant notable time saving, to the extent that after just one month we went from 3-month delivery times to just one and a half weeks, or two at the most. And all this with a general increase in the quality level as well. As a result, we've purchased a total of three Biesse machines", concludes Van Hecke.



# LIVE THE EXPERIENCE



Interconnected technologies and advanced services that maximise efficiency and productivity, generating new skills to serve better our customer.

**LIVE THE BIESSE GROUP  
EXPERIENCE AT OUR CAMPUSES  
ACROSS THE WORLD**

