

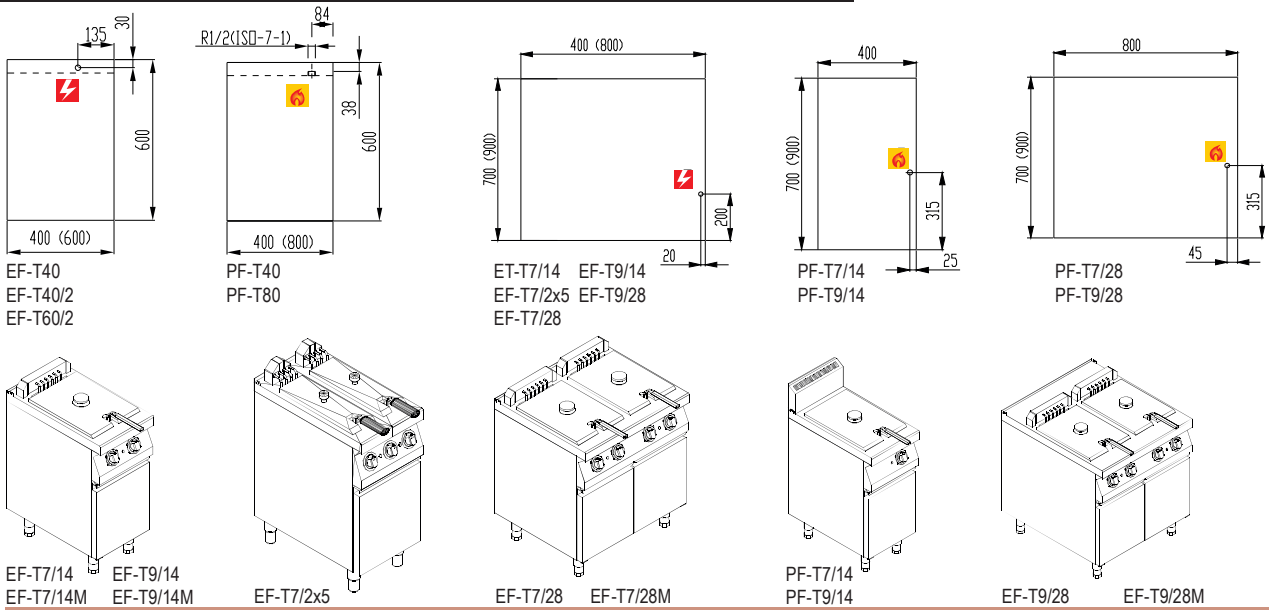

1.3 Fryers / Fritteusen / Фритюрницы





PF-T7/28

### 1.3 Fryers / Fritteusen / Фритюрницы

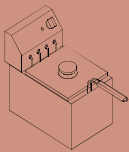

MINI FRI-6

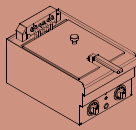

EF-T40

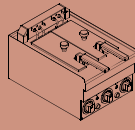

EF-T40/2

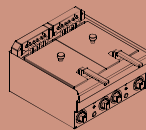

EF-T60/2

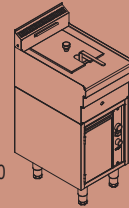

PF-T40

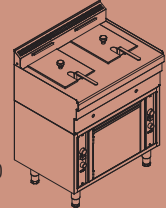

PF-T80

#### FRYERS / FRITTEUSEN / ФРИТЮРНИЦЫ

LINE / LÍNIE / ЛИНИЯ	TYPE TYP ТИП	Art. No. Art. Nr. № Prod.	DIMENSIONS ABMESSUNGEN РАЗМЕРЫ (mm/mm)		OIL QUANTITY / ÖLMENGE / КОЛ-ВО МАСЛА (л / л)	POWER RATING LEISTUNG МОЩНОСТЬ		GAS CONSUMPTION GAS VERBRAUCH РАСХОД		EL. POWER SUPPLY ELEKTROANSCHLUSS ЭЛЕКТРОПОДВОДКА	ELECTRIC CURRENT STROM СИЛА ТОКА	GAS CONNECTION GASANSCHLUSS ГАЗОВАЯ ПОДВОДКА
			Appliance Gerät Прибор	Basket Frittierkorb Корзина		Electricity Elektrizität Электричество (kW / кВт)	Gas Газ (kW / кВт)	L.P.G. Flussiggas (kg/h) С.Н.Г. (кг/ч)	Nat. Gas Erdgas (m³/h) Прир. Газ (м³/ч)			
KOGAST 600	MINI FRI-6	19151	267x405x390	210x234x110	1x 6	3,6	-	-	-	230V AC	15,7A	-
	EF-T40	53439	400x600x310	230x345x100	1 x 8-10	8,1	-	-	-	400V 3N AC	11,7A	-
	EF-T40/2	55235	400x600x310	125x275x100	2 x 4-5	2 x 3,5	-	-	-	400V 2N AC	15,2A	-
	EF-T60/2	53441	600x600x310	230x345x100	2 x 8-10	2 x 8,1	-	-	-	400V 3N AC	23,4A	-
	PF-T40	53455	400x600x310	230x300x115	1x 8-10	-	6,5	0,51	0,64	-	-	R 1/2"
	PF-T80	53456	800x600x310	230x300x115	2 x 8-10	-	2 x 6,5	1,02	1,28	-	-	R 1/2"
KOGAST 700	EF-T7/14	55862	400x700x900	230x405x120	1 x 13-15	11,1	-	-	-	400V 3N AC	16,7A	-
	EF-T7/14M	58072	400x700x900	230x405x120	1 x 13-15	14,1	-	-	-	400V 3N AC	20,4A	-
	EF-T7/2x5	57534	400x700x900	125x275x100	2x4-5	2x3,5	-	-	-	400V 2N AC	15,2 A	-
	EF-T7/28	55863	800x700x900	230x405x120	2 x 13-15	2 x 11,1	-	-	-	400V 3N AC	32,1A	-
	EF-T7/28M	58073	800x700x900	230x405x120	2 x 13-15	28,2	-	-	-	400V 3N AC	40,9A	-
	PF-T7/14	55864	400x700x900	240x285x120	1 x 14	-	11,2	0,88	1,18	-	-	R 3/4"
	PF-T7/28	55865	800x700x900	240x285x120	2 x 14	-	2 x 11,2	1,76	2,36	-	-	R 3/4"
KOGAST 900	EF-T9/14	55918	400x900x900	230x405x120	1 x 13-15	11,1	-	-	-	400V 3N AC	16,7A	-
	EF-T9/14M	58074	400x900x900	230x405x120	1 x 13-15	14,1	-	-	-	400V 3N AC	20,4A	-
	EF-T9/28	55919	800x900x900	230x405x120	2 x 13-15	2 x 11,1	-	-	-	400V 3N AC	32,1A	-
	EF-T9/28M	58075	800x900x900	230x405x120	2 x 13-15	28,2	-	-	-	400V 3N AC	40,9A	-
	PF-T9/14	55920	400x900x900	230x345x120	1 x 14	-	11,2	0,88	1,18	-	-	R 3/4"
	PF-T9/28	55921	800x900x900	230x345x120	2 x 14	-	2 x 11,2	1,76	2,36	-	-	R 3/4"

Connection / Anschluss / Подключение: - Electricity / Elektrizität / Электричество - Gas / Газ